

PARTS CATALOGUE

YZ250FW'07 (5XCK) SOUTH AFRICA

1F5XC-100E1

(2F5XC-100E1)

YZ250F/YZ250FW
PARTS CATALOGUE
©2006 by Yamaha Motor Co., Ltd.
1st edition, October 2006
All rights reserved.
Any reprinting or unauthorized use
without the written permission of
Yamaha Motor Co., Ltd.
is expressly prohibited.
Printed in Japan.

A3

FOREWORD

This Parts Catalogue is related to the parts for the model(s) on the cover page. When you are ordering replacement parts, please refer to this Parts Catalogue and quote both part numbers and part names correctly.

1. Modifications or additions which have been made after the issue of the Parts Catalogue will be announced in the Parts News.

It is advisable that you make the necessary corrections to the Parts Catalogue according to the Parts News.

2. Abbreviations

The following abbreviations are used in this Parts Catalogue.

“UR” Use specified parts number.

“UN” Use as many as needed.

“AP” Alternate Parts

“LM” Locally Made (Parts need to be ordered locally)

“F#” Frame No. (Applicable machine No.)

“O/S” Over Size

3. The number of components for assembly

- Parts, which are to be supplied in an assembly, are listed with a dot (.) in front of the part name as shown below.
- The numeral appearing to the right of each component part indicates the quantity of parts for each assembly unit.

PART NO.	DESCRIPTION	Q'TY	REMARKS
2F5-83310-60	FRONT FLASHER LIGHT ASSY	2	
115-83311-60	.BULB (6V-18W)	1	

4. Applicable colours of graphics are represented in the “REMARKS” as shown below.

PART NO.	DESCRIPTION	Q'TY	REMARKS
2N4-24110-00-X5	FUEL TANK COMP.	2	MXR
3J1-24240-10	.GRAPHIC, FUEL TANK	1	FOR MXR

5. Note that the illustrations for reference in finding parts numbers are not to be used for assembling. When assembling, please use the applicable service manual.

6. The asterisk (*) before a reference number indicates modified items after the first edition.

FOREWORD

7. Applicable Serial No.

Engine Serial No.

Frame Serial No.

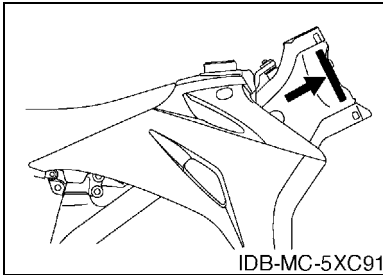
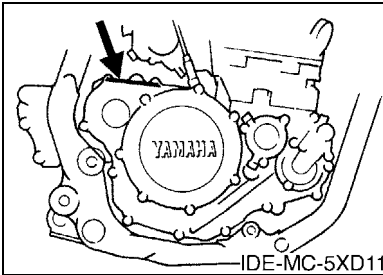

8. Applicable Colour Code (The (*) mark shows Model colour.)

Abbreviation	Colour Name	Colour Code
DPBSE(*)	DEEP PURPLISH BLUE SOLID E	0583
PWS1(*)	PURPLISH WHITE SOLID 1	0206

MODEL LABEL

- (1) A label called “Model Label” is affixed in the location as indicated in (3) below. When using this parts catalogue, please be sure to cross-reference the “model code – production code No.” in the catalogue with the “model code – production code No.” indicated on the Model Label affixed onto the product concerned.

- (2) “Model Label” Indication

<table border="0" style="width: 100%;"> <tr> <td style="text-align: center;">a</td> <td style="text-align: center;">b</td> </tr> <tr> <td style="text-align: center;">○ xxxx – xxx</td> <td style="text-align: center;">x c</td> </tr> <tr> <td style="text-align: center;">●</td> <td style="text-align: center;">c</td> </tr> </table>	a	b	○ xxxx – xxx	x c	●	c	<p>a: Model Type Code</p> <p>b: Production Code No.</p> <p>c: Colouring Type</p>	<table border="0" style="width: 100%;"> <tr> <td style="text-align: center;">○ 4TW1-010</td> </tr> <tr> <td style="text-align: center;">● A</td> </tr> </table>	○ 4TW1-010	● A
a	b									
○ xxxx – xxx	x c									
●	c									
○ 4TW1-010										
● A										

- (3) Model Label Affixing Location

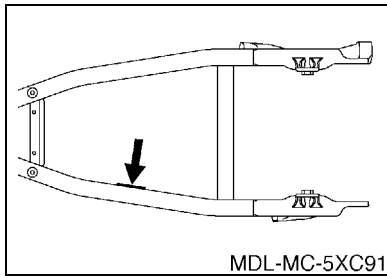

- (4) Colouring Information

Model Code	Colouring Type Code	Colour Code	Colour Name	Abbreviation
5XCG	A	0583	DEEP PURPLISH BLUE SOLID E	DPBSE
	B	0206	PURPLISH WHITE SOLID 1	PWS1
5XCH	A	0583	DEEP PURPLISH BLUE SOLID E	DPBSE
	B	0206	PURPLISH WHITE SOLID 1	PWS1
5XCJ	A	0583	DEEP PURPLISH BLUE SOLID E	DPBSE
	B	0206	PURPLISH WHITE SOLID 1	PWS1
5XCK	A	0583	DEEP PURPLISH BLUE SOLID E	DPBSE
	B	0206	PURPLISH WHITE SOLID 1	PWS1

- (5) Model Code – Production Code Number of Model Listed in This Parts Catalogue

Model Code	Production Code No.	Country (destination)	Model Code	Production Code No.	Country (destination)
5XCG	010	U.S.A.			
	020	CANADA			
5XCH	010	EUROPE			
	020	FRANCE			
5XCJ	010	JAPAN			
5XCK	010	AUSTRALIA			
		NEW ZEALAND			
		SOUTH AFRICA			

CONTENTS

ENGINE

CYLINDER	B2
CRANKSHAFT & PISTON	B4
VALVE	B5
CAMSHAFT & CHAIN	B7
WATER PUMP	B8
RADIATOR & HOSE	B9
OIL PUMP	B10
OIL CLEANER	B12
INTAKE	B13
CARBURETOR	B14
EXHAUST	C4
CRANKCASE	C5
CRANKCASE COVER 1	C6
STARTER	C8
CLUTCH	C9
TRANSMISSION	C11
SHIFT CAM & FORK	C13
SHIFT SHAFT	C14

CHASSIS

FRAME	C15
FENDER	D3
SIDE COVER & OIL TANK	D5
REAR ARM	D7
REAR SUSPENSION	D9
STEERING	D11
FRONT FORK	D12
FUEL TANK	D15
SEAT	E3
FRONT WHEEL	E4
FRONT BRAKE CALIPER	E5
REAR WHEEL	E6
REAR BRAKE CALIPER	E8
STEERING HANDLE & CABLE	E9
FRONT MASTER CYLINDER	E10
STAND & FOOTREST	E11
REAR MASTER CYLINDER	E12
GENERATOR	E13
HANDLE SWITCH & LEVER	E14
ELECTRICAL 1	E15
ALTERNATE FOR CHASSIS	F2

ALTERNATE	F3
-----------------	----

INDEX

NUMERICAL INDEX	M1
-----------------------	----

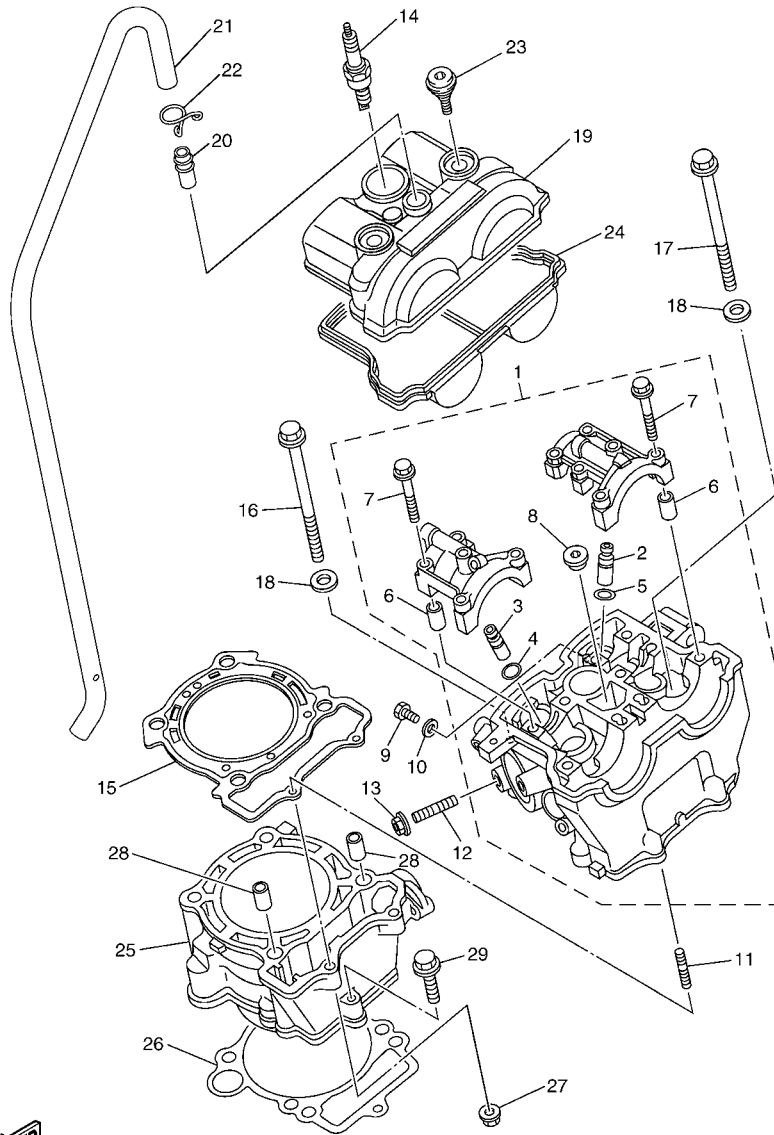

5XC100-F010

FIG. 1 CYLINDER

REF. NO.	PART NO.	DESCRIPTION	5XCG	5XCH	5XCJ	5XCK	REMARKS
1	5XC-11102-20	CYLINDER HEAD ASSY	1	1	1	1	
2	5XC-11133-10	.GUIDE, VALVE 1	3	3	3	3	
3	5NL-11134-10	.GUIDE, VALVE 2	2	2	2	2	
4	93440-10153	.CIRCLIP	2	2	2	2	
5	93440-07149	.CIRCLIP	3	3	3	3	
6	91808-16023	.PIN, DOWEL	4	4	4	4	
7	90105-06027	.BOLT, FLANGE	10	10	10	10	
8	90340-12007	.PLUG, STRAIGHT SCREW	1	1	1	1	
9	95022-06010	BOLT, FLANGE	1	1	1	1	
10	90430-06014	GASKET	1	1	1	1	
11	90116-06038	BOLT, STUD	2	2	2	2	
12	95612-08620	BOLT, STUD	2	2	2	2	
13	95702-08500	NUT, FLANGE	2	2	2	2	
14	94701-00411	PLUG, SPARK (NGK R CR8E)	1	1	1	1	STD
	94701-00410	PLUG, SPARK (NGK R CR9E)	1	1	1	1	AP
15	5NL-11181-00	GASKET, CYLINDER HEAD 1	1	1	1	1	
16	90105-09004	BOLT, FLANGE	2	2	2	2	
17	90105-09002	BOLT, FLANGE	2	2	2	2	
18	90201-096J9	WASHER, PLATE	4	4	4	4	
19	5NL-11191-20	COVER, CYLINDER HEAD 1	1	1	1	1	
20	371-11167-01	PIPE, BREATHER 2	1	1	1	1	
21	5XC-11166-00	PIPE, BREATHER 1	1	1	1	1	
22	90467-140A4	CLIP	1	1	1	1	
23	5UM-1119E-00	BOLT, COVER HEAD	2	2	2	2	
24	5NL-11193-00	GASKET, HEAD COVER 1	1	1	1	1	

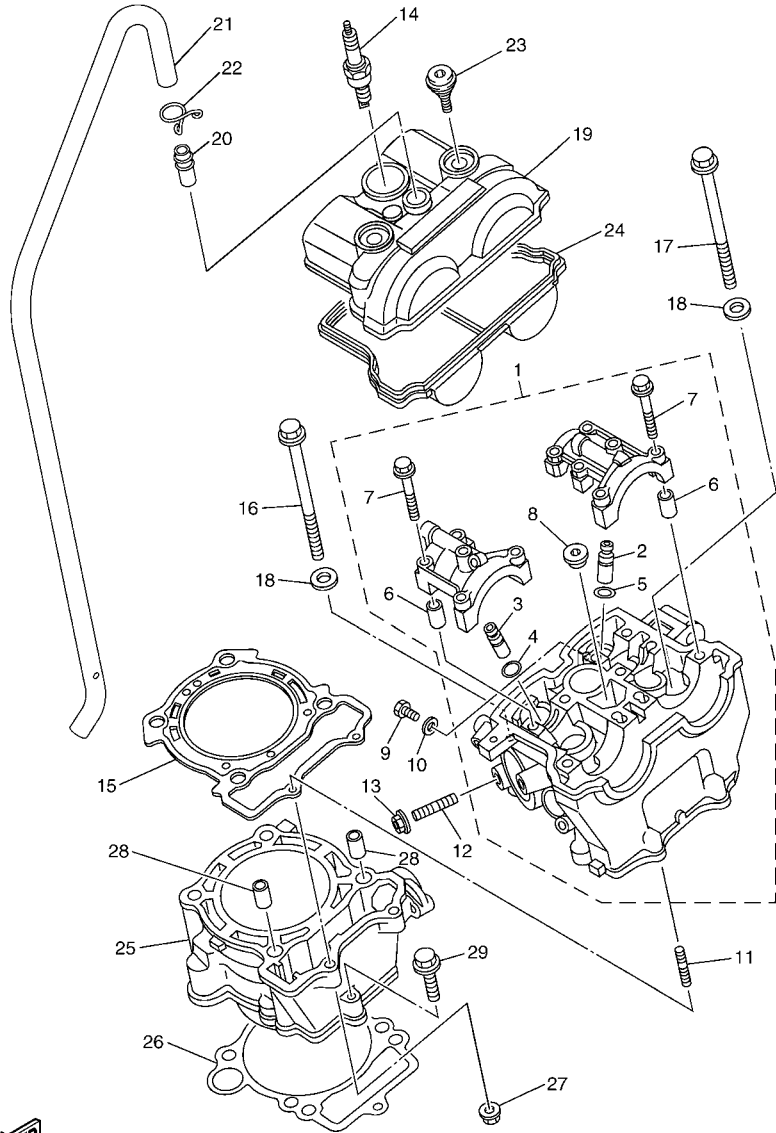

5XCG100-F010

FIG. 1 CYLINDER

REF. NO.	PART NO.	DESCRIPTION	5XCG	5XCH	5XCJ	5XCK	REMARKS
25	5XC-11311-10	CYLINDER 1	1	1	1	1	
26	5NL-11351-00	GASKET, CYLINDER	1	1	1	1	
27	95702-06500	NUT, FLANGE	2	2	2	2	
28	93612-16254	PIN, DOWEL	2	2	2	2	
29	95022-06035	BOLT, FLANGE	1	1	1	1	

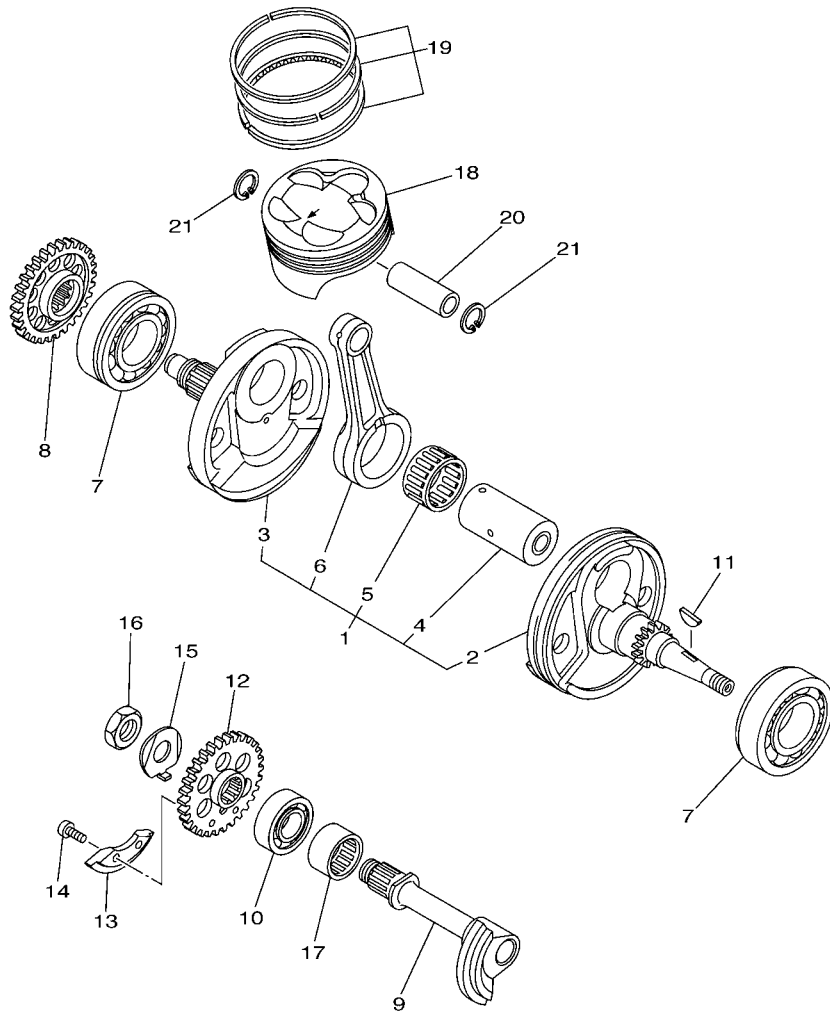
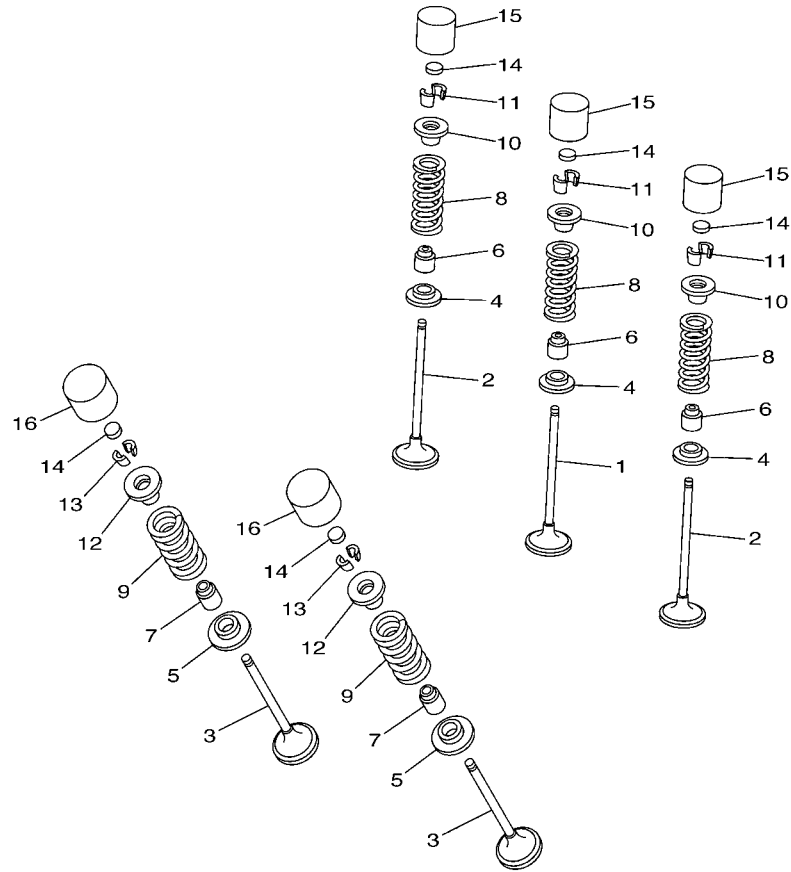

FIG. 2 CRANKSHAFT & PISTON

REF. NO.	PART NO.	DESCRIPTION	5XCG	5XCH	5XCJ	5XCK	REMARKS
1	5XC-11400-20	CRANKSHAFT ASSY	1	1	1	1	
2	5UL-11412-20	.CRANK 1	1	1	1	1	
3	5UL-11422-10	.CRANK 2	1	1	1	1	
4	5XC-11681-00	.PIN, CRANK 1	1	1	1	1	
5	93310-63238	.BEARING	1	1	1	1	
6	5XC-11651-00	.ROD, CONNECTING	1	1	1	1	
7	93306-20648	BEARING	2	2	2	2	
8	5NL-11536-00	GEAR, DRIVE	1	1	1	1	
9	5NL-11455-00	SHAFT 1	1	1	1	1	
10	93306-20335	BEARING	1	1	1	1	
11	90280-03006	KEY, WOODRUFF	1	1	1	1	
12	5NL-11531-00	GEAR, BALANCE WEIGHT	1	1	1	1	
13	5NL-11454-00	WEIGHT 1	1	1	1	1	
14	90149-06084	SCREW	2	2	2	2	
15	90215-14204	WASHER, LOCK	1	1	1	1	
16	90170-14171	NUT	1	1	1	1	
17	93311-32261	BEARING	1	1	1	1	
18	5NL-11631-20	PISTON (STD)	1	1	1	1	
19	5NL-11603-00	PISTON RING SET (STD)	1	1	1	1	
20	5NL-11633-00	PIN, PISTON	1	1	1	1	
21	93420-16086	CIRCLIP	2	2	2	2	



5XCG100-F020



5NL1100-1030

FIG. 3 VALVE

REF. NO.	PART NO.	DESCRIPTION	5XCG	5XCH	5XCJ	5XCK	REMARKS
1	5NL-12111-20	VALVE, INTAKE	1	1	1	1	
2	5NL-12112-20	VALVE, INTAKE 2	2	2	2	2	
3	5NL-12121-10	VALVE, EXHAUST	2	2	2	2	
4	5NL-12116-00	SEAT, VALVE SPRING	3	3	3	3	
5	3GM-12126-00	SEAT, VALVE SPRING 2	2	2	2	2	
6	4TV-12119-00	SEAL, VALVE STEM	3	3	3	3	
7	4SV-12119-00	SEAL, VALVE STEM	2	2	2	2	
8	5NL-12113-00	SPRING, VALVE INNER	3	3	3	3	
9	5NL-12114-00	SPRING, VALVE OUTER	2	2	2	2	
10	1HX-12117-00	RETAINER, VALVE SPRING	3	3	3	3	
11	1HX-12118-00	COTTER, VALVE	6	6	6	6	
12	1WG-12117-00	RETAINER, VALVE SPRING	2	2	2	2	
13	1WG-12118-00	COTTER, VALVE	4	4	4	4	
14	1HX-12168-00	PAD, ADJUSTING 2 (1.20)	5	5	5	5	UR
	1HX-12168-20	PAD, ADJUSTING 2 (1.25)	5	5	5	5	UR
	1HX-12168-40	PAD, ADJUSTING 2 (1.30)	5	5	5	5	UR
	1HX-12168-60	PAD, ADJUSTING 2 (1.35)	5	5	5	5	UR
	1HX-12168-80	PAD, ADJUSTING 2 (1.40)	5	5	5	5	UR
	1HX-12168-A0	PAD, ADJUSTING 2 (1.45)	5	5	5	5	UR
	1HX-12168-F0	PAD, ADJUSTING 2 (1.50)	5	5	5	5	UR
	1HX-12168-H1	PAD, ADJUSTING 2 (1.55)	5	5	5	5	UR
	1HX-12168-K1	PAD, ADJUSTING 2 (1.60)	5	5	5	5	UR
	1HX-12168-M1	PAD, ADJUSTING 2 (1.65)	5	5	5	5	UR
	1HX-12168-R1	PAD, ADJUSTING 2 (1.70)	5	5	5	5	UR
	1HX-12168-U1	PAD, ADJUSTING 2 (1.75)	5	5	5	5	UR
	1HX-12168-W1	PAD, ADJUSTING 2 (1.80)	5	5	5	5	UR
	1HX-12168-Y1	PAD, ADJUSTING 2 (1.85)	5	5	5	5	UR

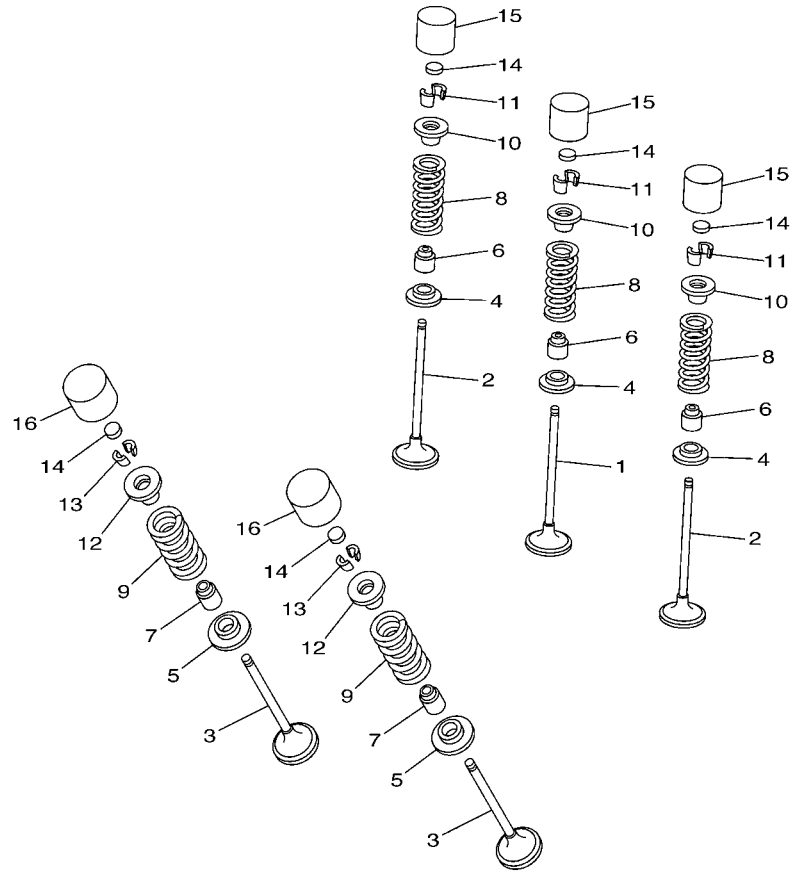

5NL1100-1030

FIG. 3 VALVE

REF. NO.	PART NO.	DESCRIPTION	5XCG	5XCH	5XCJ	5XCK	REMARKS
14	1HX-12169-11	PAD, ADJUSTING 2 (1.90)	5	5	5	5	UR
	1HX-12169-31	PAD, ADJUSTING 2 (1.95)	5	5	5	5	UR
	1HX-12169-50	PAD, ADJUSTING 2 (2.00)	5	5	5	5	UR
	1HX-12169-70	PAD, ADJUSTING 2 (2.05)	5	5	5	5	UR
	1HX-12169-90	PAD, ADJUSTING 2 (2.10)	5	5	5	5	UR
	1HX-12169-E0	PAD, ADJUSTING 2 (2.15)	5	5	5	5	UR
	1HX-12169-G0	PAD, ADJUSTING 2 (2.20)	5	5	5	5	UR
	1HX-12169-J0	PAD, ADJUSTING 2 (2.25)	5	5	5	5	UR
	1HX-12169-L0	PAD, ADJUSTING 2 (2.30)	5	5	5	5	UR
	1HX-12169-N0	PAD, ADJUSTING 2 (2.35)	5	5	5	5	UR
	1HX-12169-T0	PAD, ADJUSTING 2 (2.40)	5	5	5	5	UR
15	3LN-12153-10	LIFTER, VALVE	3	3	3	3	YELLOW
16	3FV-12153-10	LIFTER, VALVE	2	2	2	2	YELLOW

B6

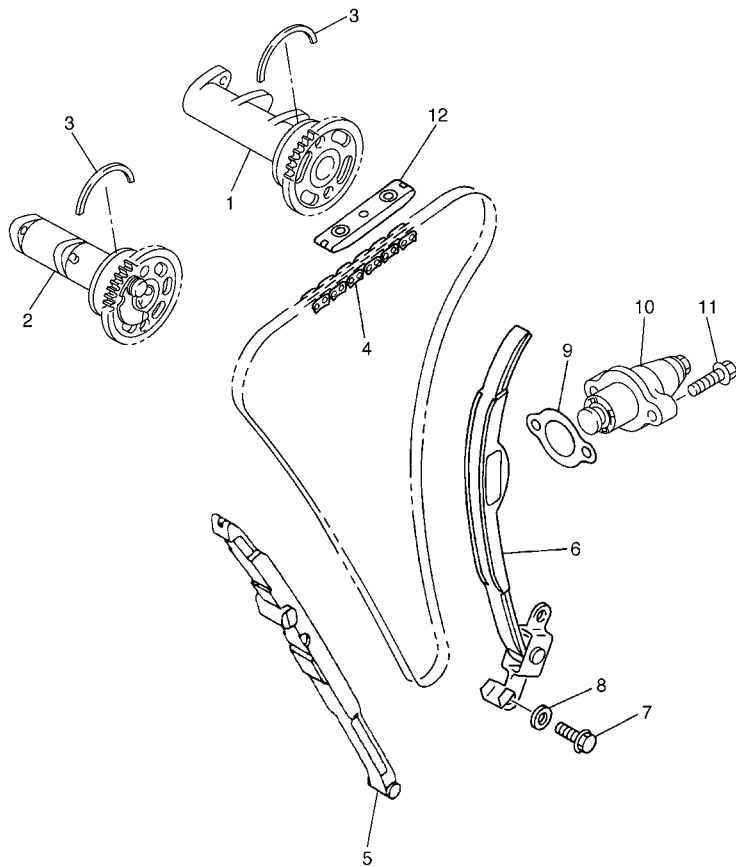
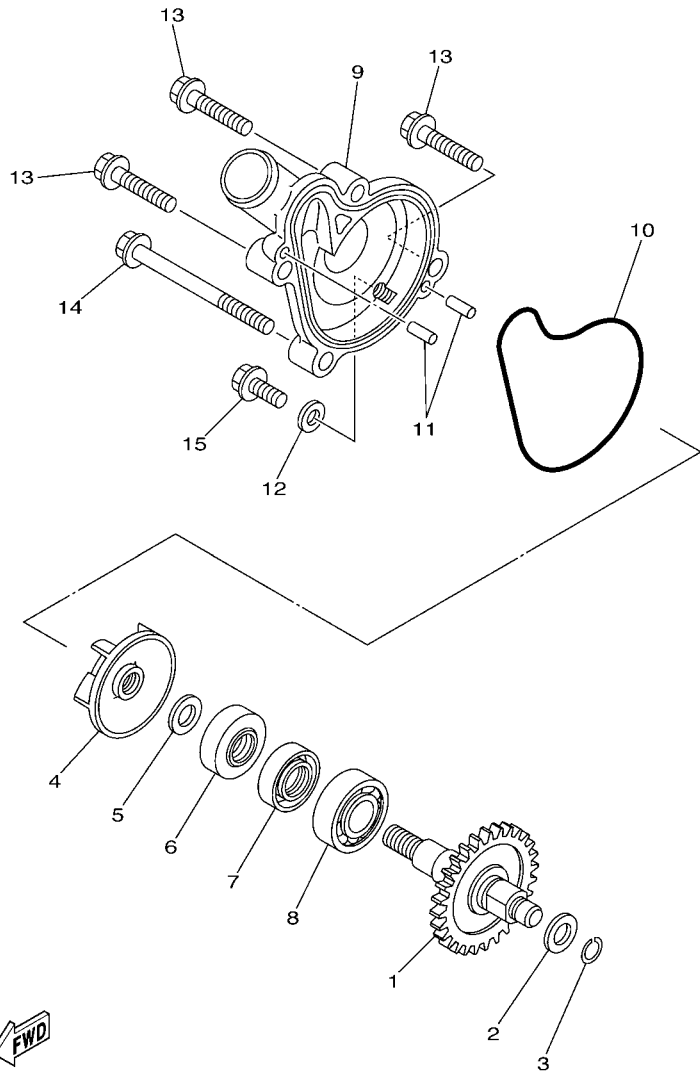

FIG. 4 CAMSHAFT & CHAIN

REF. NO.	PART NO.	DESCRIPTION	5XCG	5XCH	5XCJ	5XCK	REMARKS
1	5UL-12170-10	CAMSHAFT ASSY 1	1	1	1	1	
2	5UL-12180-10	CAMSHAFT ASSY 2	1	1	1	1	
3	93440-41178	CIRCLIP	2	2	2	2	
4	94591-53114	CHAIN	1	1	1	1	
5	5NL-12251-10	DAMPER, CHAIN 1	1	1	1	1	
6	5NL-12252-00	DAMPER, CHAIN 2	1	1	1	1	
7	97022-06016	BOLT	2	2	2	2	
8	92902-06600	WASHER, PLATE	2	2	2	2	
9	4FM-12213-00	GASKET, TENSIONER CASE	1	1	1	1	
10	5TA-12210-20	TENSIONER ASSY, CAM CHAIN	1	1	1	1	
11	95022-06025	BOLT, FLANGE	2	2	2	2	
12	5BE-12241-00	GUIDE, STOPPER 2	1	1	1	1	



5XC9100-E040



5NL1100-1050

FIG. 5 WATER PUMP

REF. NO.	PART NO.	DESCRIPTION	5XC	5XCH	5XCJ	5XCK	REMARKS
1	5XC-12459-00	GEAR, IMPELLER SHAFT	1	1	1	1	
2	90201-08512	WASHER, PLATE	1	1	1	1	
3	93440-07182	CIRCLIP	1	1	1	1	
4	5DH-12451-00	IMPELLER, WATER PUMP	1	1	1	1	
5	90201-08512	WASHER, PLATE	1	1	1	1	
6	93109-11073	OIL SEAL	1	1	1	1	
7	93102-12106	OIL SEAL (SD 12-22-5 HS)	1	1	1	1	
8	93306-00105	BEARING	1	1	1	1	
9	5NL-12422-10	COVER, HOUSING	1	1	1	1	
10	5NL-12439-00	O-RING	1	1	1	1	
11	93604-10011	PIN, DOWEL	2	2	2	2	
12	90430-06014	GASKET	1	1	1	1	
13	95022-06025	BOLT, FLANGE	3	3	3	3	
14	95022-06065	BOLT, FLANGE	1	1	1	1	
15	95022-06012	BOLT, FLANGE	1	1	1	1	

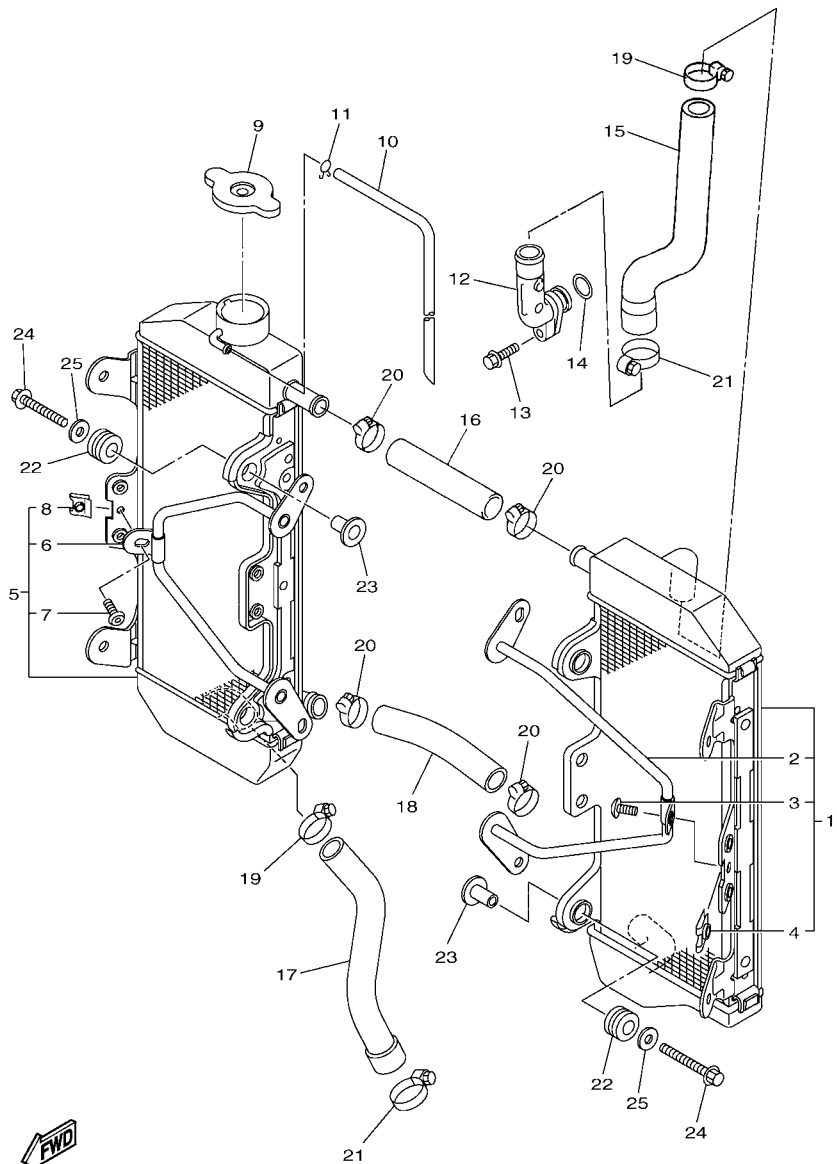

5XCG100-F060

FIG. 6 RADIATOR & HOSE

REF. NO.	PART NO.	DESCRIPTION	5XCG	5XCH	5XCJ	5XCK	REMARKS
1	5XC-1240A-G0	RADIATOR ASSY	1	1	1	1	
2	2S2-12464-70	.STAY, RADIATOR	1	1	1	1	
3	92012-06010	.BOLT, BUTTON HEAD	3	3	3	3	
4	90183-060A6	.NUT, SPRING	1	1	1	1	
5	5XC-12461-G0	RADIATOR ASSY	1	1	1	1	
6	2S2-12464-70	.STAY, RADIATOR	1	1	1	1	
7	92012-06010	.BOLT, BUTTON HEAD	3	3	3	3	
8	90183-060A6	.NUT, SPRING	1	1	1	1	
9	22W-12462-00	CAP, RADIATOR	1	1	1	1	
10	91A20-05065	TUBE, FLEXIBLE VINYL	1	1	1	1	
11	90467-090A2	CLIP	1	1	1	1	
12	5XC-12481-G0	PIPE 1	1	1	1	1	
13	91312-06020	BOLT	1	1	1	1	
14	93210-16275	O-RING	1	1	1	1	
15	5XC-12576-G0	HOSE 1	1	1	1	1	
16	1C3-12482-00	PIPE 2	1	1	1	1	
17	5XC-12578-G0	HOSE 3	1	1	1	1	
18	5XC-12579-G0	HOSE 4	1	1	1	1	
19	90450-25001	HOSE CLAMP ASSY	2	2	2	2	
20	90450-22001	HOSE CLAMP ASSY	4	4	4	4	
21	90450-32003	HOSE CLAMP ASSY	2	2	2	2	
22	90480-15528	GROMMET	4	4	4	4	
23	90387-06065	COLLAR	4	4	4	4	
24	90105-06111	BOLT, FLANGE	4	4	4	4	
25	90201-06571	WASHER, PLATE	4	4	4	4	

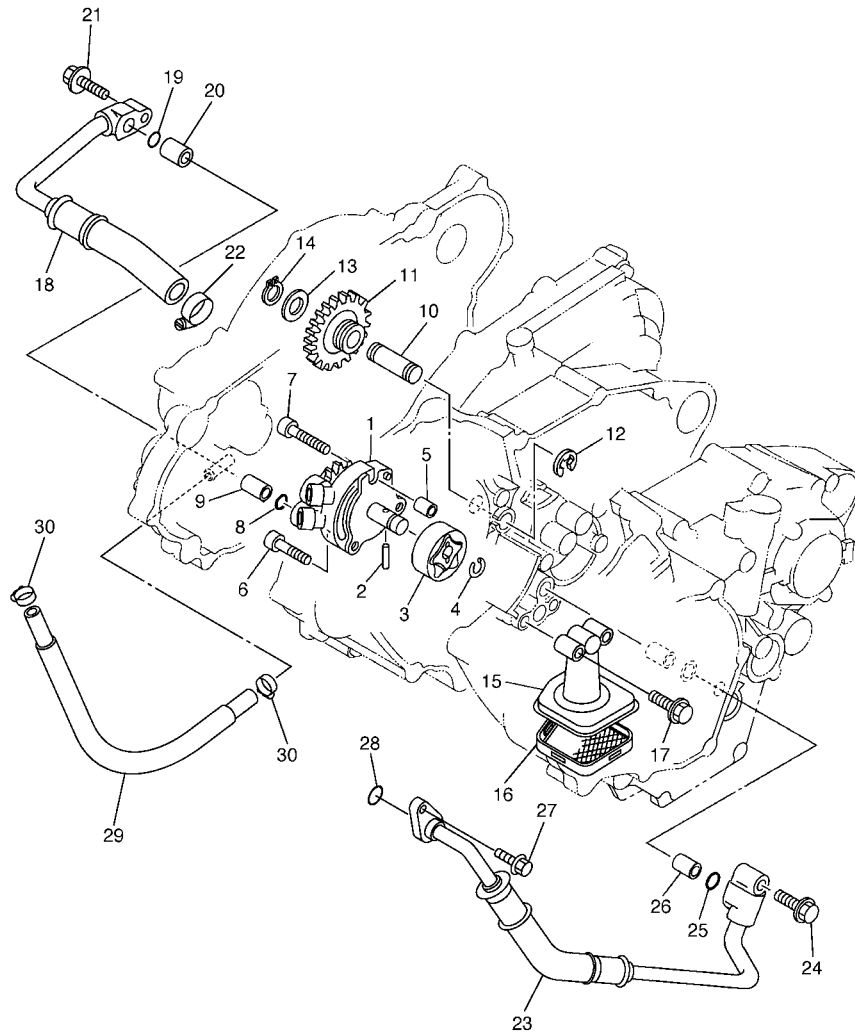

5XC9100-E070

FIG. 7 OIL PUMP

REF. NO.	PART NO.	DESCRIPTION	5XCG	5XCH	5XCJ	5XCK	REMARKS
1	5SG-13300-00	OIL PUMP ASSY	1	1	1	1	
2	93603-16219	PIN, DOWEL	1	1	1	1	
3	5NL-13320-00	ROTOR ASSY 2	1	1	1	1	
4	93440-10153	CIRCLIP	1	1	1	1	
5	99530-08012	PIN, DOWEL	1	1	1	1	
6	91312-06025	BOLT	2	2	2	2	
7	91317-06030	BOLT	1	1	1	1	
8	93210-10197	O-RING	1	1	1	1	
9	99530-10114	PIN, DOWEL	1	1	1	1	
10	5BE-13342-00	SHAFT, IDLE GEAR	1	1	1	1	
11	5NL-13341-00	GEAR, OIL PUMP IDLE	1	1	1	1	
12	99001-08600	CIRCLIP	1	1	1	1	
13	90201-12166	WASHER, PLATE	1	1	1	1	
14	99009-12400	CIRCLIP	1	1	1	1	
15	5XC-13412-00	HOUSING, STRAINER	1	1	1	1	
16	5NL-13411-00	STRAINER, OIL	1	1	1	1	
17	95022-06025	BOLT, FLANGE	2	2	2	2	
18	5XC-13464-30	HOSE, OIL 1	1	1	1	1	
19	93210-10197	O-RING	1	1	1	1	
20	99530-10114	PIN, DOWEL	1	1	1	1	
21	95022-06025	BOLT, FLANGE	1	1	1	1	
22	90450-22001	HOSE CLAMP ASSY	1	1	1	1	
23	5XC-13465-30	HOSE, OIL 2	1	1	1	1	
24	95022-06025	BOLT, FLANGE	1	1	1	1	
25	93210-10197	O-RING	1	1	1	1	
26	99530-10114	PIN, DOWEL	1	1	1	1	
27	95022-06016	BOLT, FLANGE	1	1	1	1	

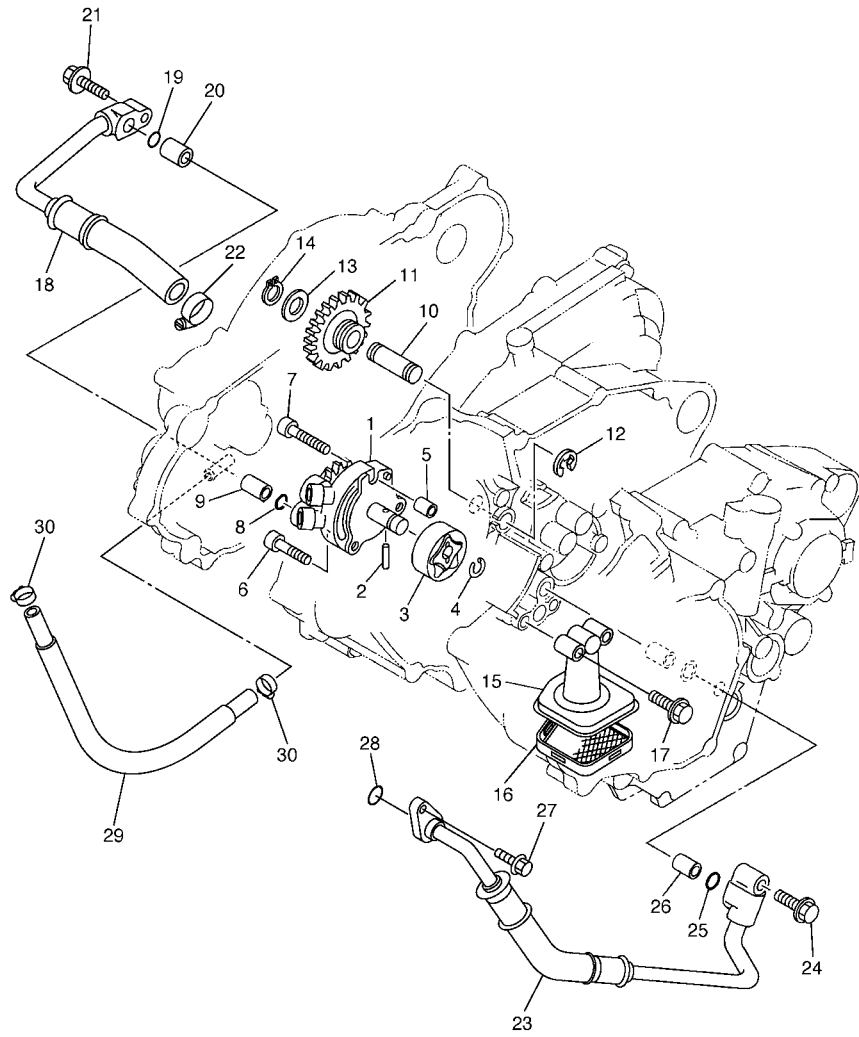

5XC9100-E070

FIG. 7 OIL PUMP

REF. NO.	PART NO.	DESCRIPTION	5XCG	5XCH	5XCJ	5XCK	REMARKS
28	93210-09754	O-RING	1	1	1	1	
29	90445-14010	HOSE	1	1	1	1	
30	90450-17001	HOSE CLAMP ASSY	2	2	2	2	

FIG. 8 OIL CLEANER

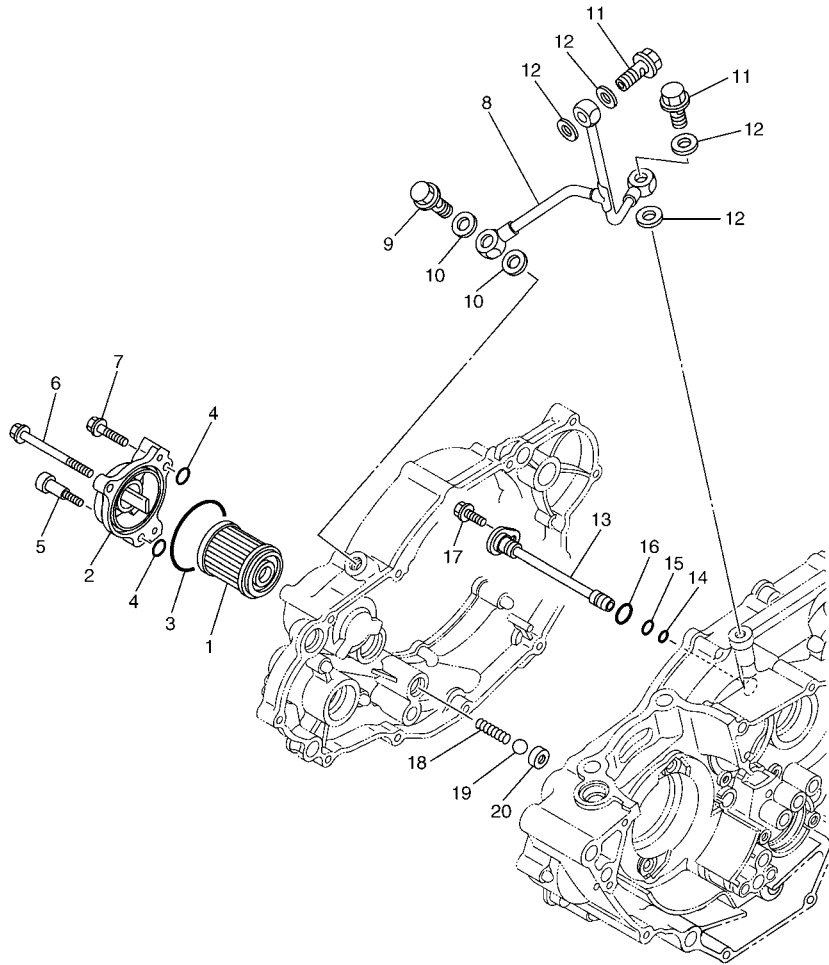

REF. NO.	PART NO.	DESCRIPTION	5XCG	5XCH	5XCJ	5XCK	REMARKS
1	5TA-13440-00	ELEMENT ASSY, OIL CLEANER	1	1	1	1	
2	5BE-13447-10	COVER, OIL ELEMENT	1	1	1	1	
3	93210-47675	O-RING	1	1	1	1	
4	93210-07135	O-RING	3	3	3	3	
5	90110-06228	BOLT, HEXAGON SOCKET HEAD	1	1	1	1	
6	91312-06065	BOLT	1	1	1	1	
7	91312-06025	BOLT	1	1	1	1	
8	5NL-13161-20	PIPE, DELIVERY 1	1	1	1	1	
9	90401-10015	BOLT, UNION	1	1	1	1	
10	90430-10188	GASKET	2	2	2	2	
11	90401-08006	BOLT, UNION	2	2	2	2	
12	90430-08119	GASKET	4	4	4	4	
13	5NL-13171-00	PIPE, DELIVERY 2	1	1	1	1	
14	93210-07003	O-RING	1	1	1	1	
15	93210-09008	O-RING	1	1	1	1	
16	93210-12759	O-RING	1	1	1	1	
17	95022-06012	BOLT, FLANGE	1	1	1	1	
18	90501-043E0	SPRING, COMPRESSION	1	1	1	1	
19	93503-08007	BALL	1	1	1	1	
20	583-13113-00	SEAT, CHECK BALL	1	1	1	1	



5XCG100-F080

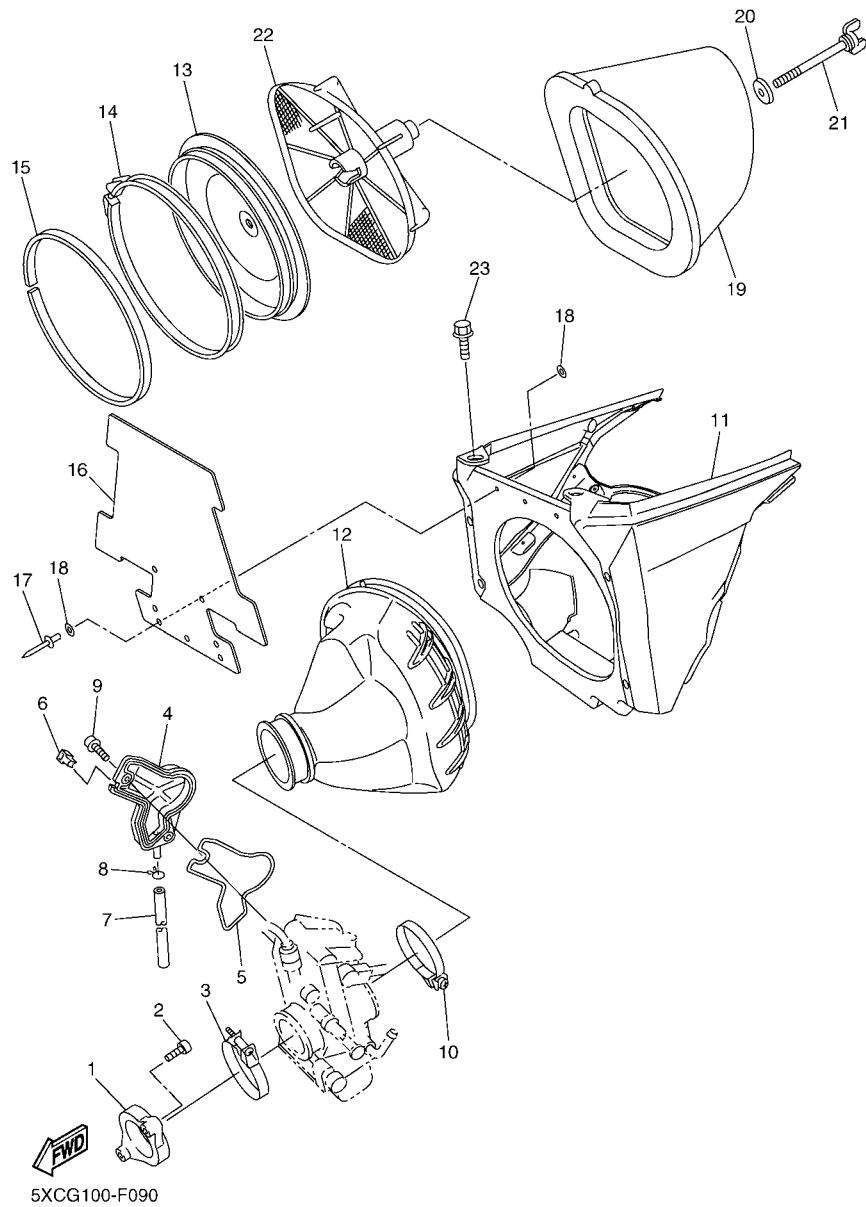

FIG. 9 INTAKE

REF. NO.	PART NO.	DESCRIPTION	5XCG	5XCH	5XCJ	5XCK	REMARKS
1	5XC-13597-30	JOINT, CARBURETOR 3	1	1	1	1	
2	91312-06025	BOLT	2	2	2	2	
3	90450-57010	HOSE CLAMP ASSY	1	1	1	1	
4	5TA-14293-00	COVER 1	1	1	1	1	
5	5TA-14227-00	GASKET	1	1	1	1	
6	5TA-14239-00	SEAL	1	1	1	1	
7	5TA-14987-00	HOSE	1	1	1	1	
8	3TJ-14137-40	CLIP	1	1	1	1	
9	90110-05038	BOLT, HEXAGON SOCKET HEAD	2	2	2	2	
10	90450-61002	HOSE CLAMP ASSY	1	1	1	1	
11	2S2-14401-70	AIR CLEANER CASE ASSY	1	1	1	1	
12	5XC-14453-G0	JOINT, AIR CLEANER 1	1	1	1	1	
13	5NY-14459-00	HOLDER, GUIDE	1	1	1	1	
14	5NY-14455-20	BAND	1	1	1	1	
15	5NY-14442-00	SPACER	1	1	1	1	
16	5XC-14417-90	COVER 1	1	1	1	1	
17	90267-32070	RIVET, BLIND	3	3	3	3	
18	90201-03313	WASHER, PLATE	6	6	6	6	
19	4XM-14451-00	ELEMENT, AIR CLEANER	1	1	1	1	
20	90209-06014	WASHER	1	1	1	1	
21	90122-06005	BOLT, WING	1	1	1	1	
22	5BE-14458-00	GUIDE	1	1	1	1	
23	90109-067F4	BOLT	2	2	2	2	

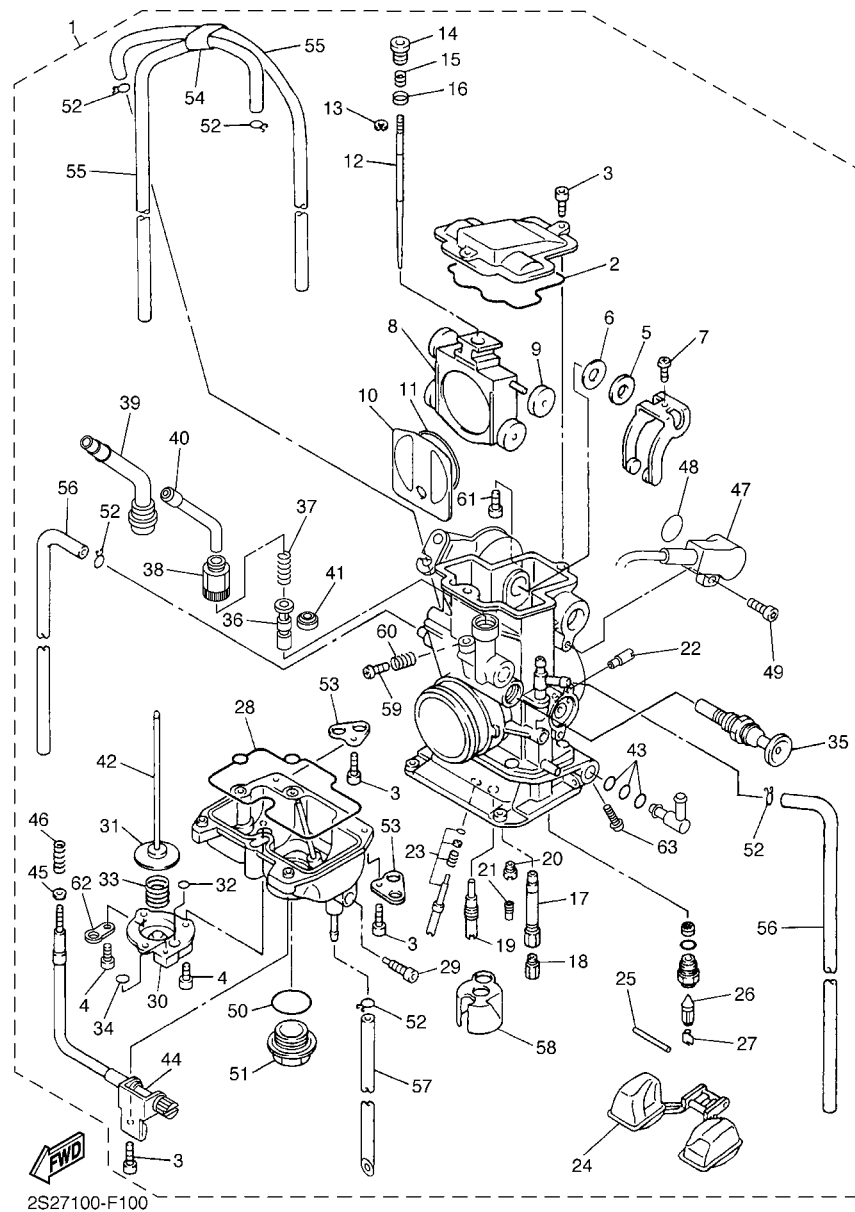
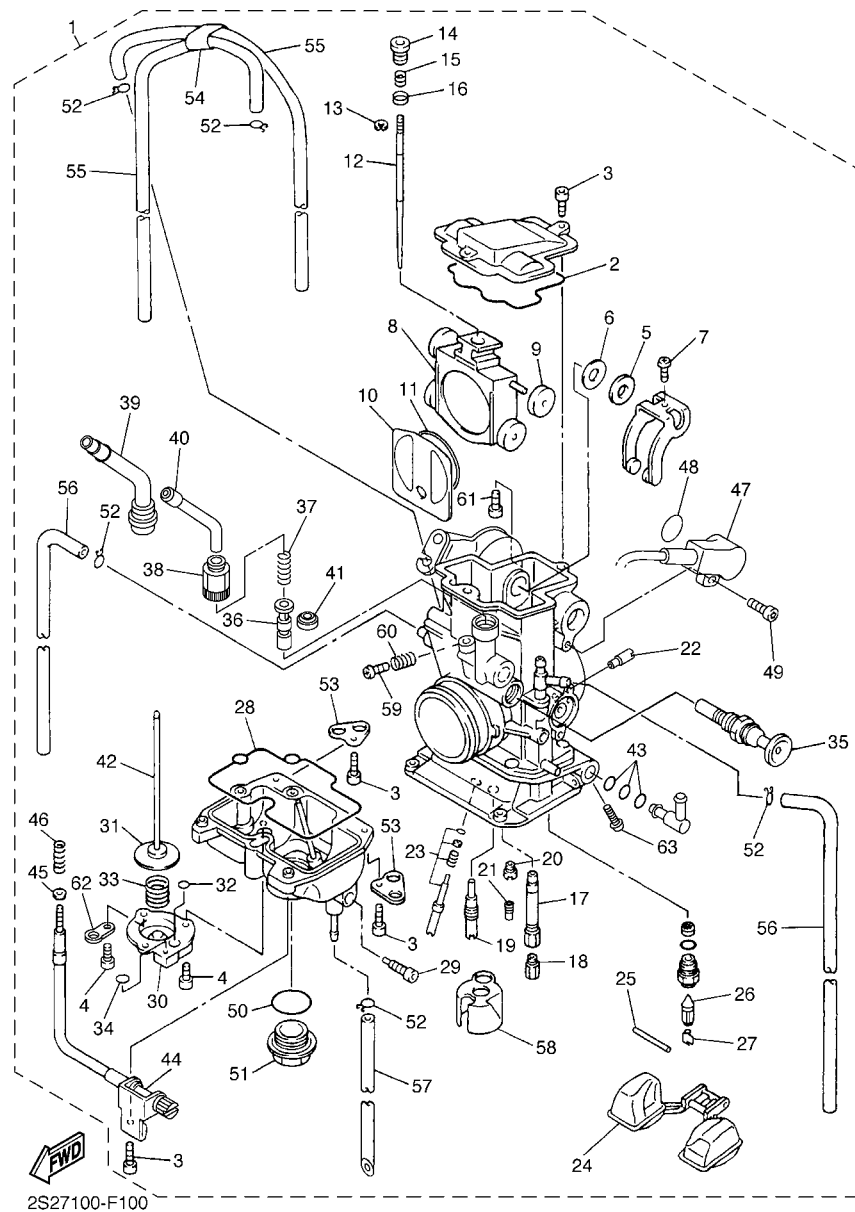

FIG. 10 CARBURETOR

REF. NO.	PART NO.	DESCRIPTION	5XCG	5XCH	5XCJ	5XCK	REMARKS
1	5XC-14101-H0	CARBURETOR ASSY 1				1	
2	5JG-14959-00	.GASKET	1	1	1	1	
3	91316-04012	.BOLT	6	6	6	6	
4	688-14592-00	.SCREW	3	3	3	3	
5	90202-08045	.WASHER, PLATE	1	1	1	1	
6	5JG-14951-00	.WASHER	1	1	1	1	
7	5JG-14522-00	.SCREW, ADJUST	1	1	1	1	
8	2S2-14388-00	.VALVE, VACUUM CONTROL	1	1	1	1	
9	3TJ-14267-40	.ROLLER	1	1	1	1	
10	5JG-14546-01	.VALVE, NEEDLE	1	1	1	1	
11	4FN-14997-00	.SEAL	1	1	1	1	
12	5NL-14916-P1	.NEEDLE (#OBE PQ)	1	1	1	1	STD
	5NL-14916-PM	.NEEDLE (#OBE PM)	1	1	1	1	AP
	5NL-14916-PN	.NEEDLE (#OBE PN)	1	1	1	1	AP
	5NL-14916-PP	.NEEDLE (#OBE PP)	1	1	1	1	AP
	5NL-14916-PR	.NEEDLE (#OBE PR)	1	1	1	1	AP
	5NL-14916-PS	.NEEDLE (#OBE PS)	1	1	1	1	AP
	5NL-14916-PT	.NEEDLE (#OBE PT)	1	1	1	1	AP
13	3TJ-14159-40	.CLIP	1	1	1	1	
14	5JG-14521-00	.SCREW, ADJUST	1	1	1	1	
15	5JG-14275-00	.SPRING	1	1	1	1	
16	5JG-14264-00	.COLLAR	1	1	1	1	
17	5XC-14947-00	.JET, NEEDLE	1	1	1	1	
18	4MX-14943-93	.JET, MAIN (#178)	1	1	1	1	STD
	4MX-14943-91	.JET, MAIN (#168)	1	1	1	1	AP
	4MX-14943-41	.JET, MAIN (#170)	1	1	1	1	AP



2S27100-F100

FIG. 10 CARBURETOR

REF. NO.	PART NO.	DESCRIPTION	5XCG	5XCH	5XCJ	5XCK	REMARKS
18	4MX-14943-92	.JET, MAIN (#172)	1	1	1	1	AP
	4MX-14943-42	.JET, MAIN (#175)	1	1	1	1	AP
	4MX-14943-43	.JET, MAIN (#180)	1	1	1	1	AP
	4MX-14943-94	.JET, MAIN (#182)	1	1	1	1	AP
	4MX-14943-44	.JET, MAIN (#185)	1	1	1	1	AP
	4MX-14943-95	.JET, MAIN (#188)	1	1	1	1	AP
19	4MX-14948-04	.JET, SLOW (#42)	1	1	1	1	STD
	4MX-14948-02	.JET, SLOW (#38)	1	1	1	1	AP
	4MX-14948-03	.JET, SLOW (#40)	1	1	1	1	AP
	4MX-14948-05	.JET, SLOW (#45)	1	1	1	1	AP
	4MX-14948-06	.JET, SLOW (#48)	1	1	1	1	AP
20	3TJ-1494F-16	.JET (#72)	1	1	1	1	STD
	3TJ-1494F-13	.JET (#65)	1	1	1	1	AP
	3TJ-1494F-14	.JET (#68)	1	1	1	1	AP
	3TJ-1494F-15	.JET (#70)	1	1	1	1	AP
	3TJ-1494F-17	.JET (#75)	1	1	1	1	AP
	3TJ-1494F-18	.JET (#78)	1	1	1	1	AP
	3TJ-1494F-19	.JET (#80)	1	1	1	1	AP
21	4JT-1494F-15	.JET (#70)				1	STD
	4JT-1494F-03	.JET (#40)		1	1	1	AP
	4JT-1494F-07	.JET (#50)	1	1	1	1	AP
	4JT-1494F-11	.JET (#60)	1	1	1	1	AP
	4JT-1494F-19	.JET (#80)		1	1	1	AP
	4JT-1494F-23	.JET (#90)	1	1	1	1	AP
	4JT-1494F-27	.JET(#100)	1	1	1	1	AP

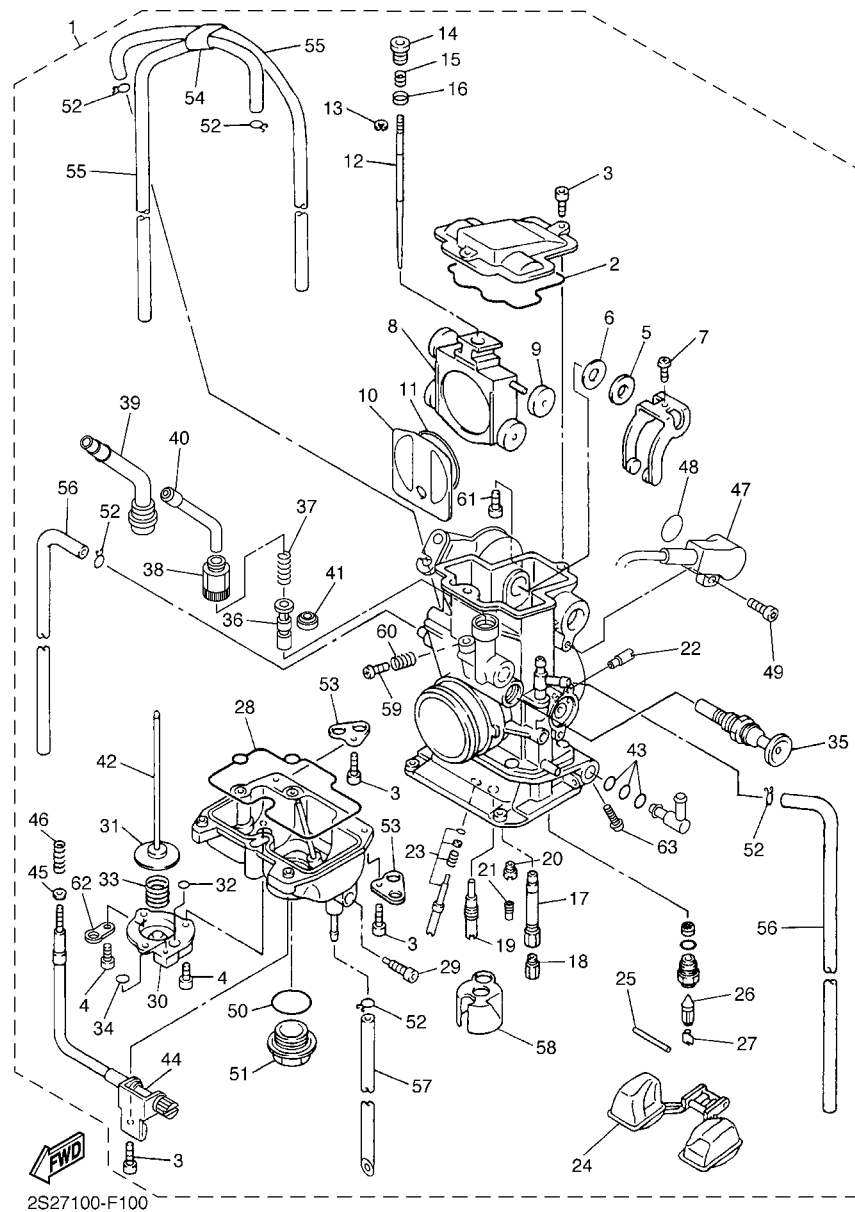

2S27100-F100

FIG. 10 CARBURETOR

REF. NO.	PART NO.	DESCRIPTION	5XCG	5XCH	5XCJ	5XCK	REMARKS
21	4JT-1494F-29	.JET(#110)	1				AP
22	5TA-14943-28	.JET, MAIN (#105)	1	1	1	1	
23	5NL-14105-00	.PILOT SCREW SET	1	1	1	1	
24	4SR-14985-00	.FLOAT	1	1	1	1	
25	676-14548-00	.PIN, FLOAT ARM	1	1	1	1	
26	4MX-14392-00	.VALVE, NEEDLE	1	1	1	1	
27	633-14159-00	.CLIP	1	1	1	1	
28	5JG-14984-00	.GASKET, FLOAT CHAMBER	1	1	1	1	
29	3TJ-14191-40	.PLUG, DRAIN	1	1	1	1	
30	3TJ-14293-40	.COVER 1	1	1	1	1	
31	5JG-14940-76	.DIAPHRAGM ASSY	1	1	1	1	STD
	5JG-14940-16	.DIAPHRAGM ASSY	1	1	1	1	AP
	5JG-14940-17	.DIAPHRAGM ASSY	1	1	1	1	AP
	5JG-14940-18	.DIAPHRAGM ASSY	1	1	1	1	AP
32	3TJ-14536-40	.GASKET	1	1	1	1	
33	3TJ-14933-40	.SPRING, DIAPHRAGM	1	1	1	1	
34	6H4-14561-00	.O-RING	1	1	1	1	
35	5XC-14171-00	.PLUNGER, STARTER	1	1	1	1	
36	5TA-14371-00	.PLUNGER, STARTER	1	1	1	1	
37	5TA-14335-00	.SPRING, PLUNGER	1	1	1	1	
38	5TA-14991-00	.SCREW	1	1	1	1	
39	2S2-14374-00	.CAP, PLUNGER	1	1	1	1	
40	5TA-14155-00	.GUIDE, CABLE	1	1	1	1	
41	5TA-14997-00	.SEAL	1	1	1	1	
42	5JG-14379-00	.ROD, STARTER	1	1	1	1	
43	3TJ-14564-40	.O-RING	3	3	3	3	
44	5XC-14922-00	.SCREW, THROTTLE	1	1	1	1	

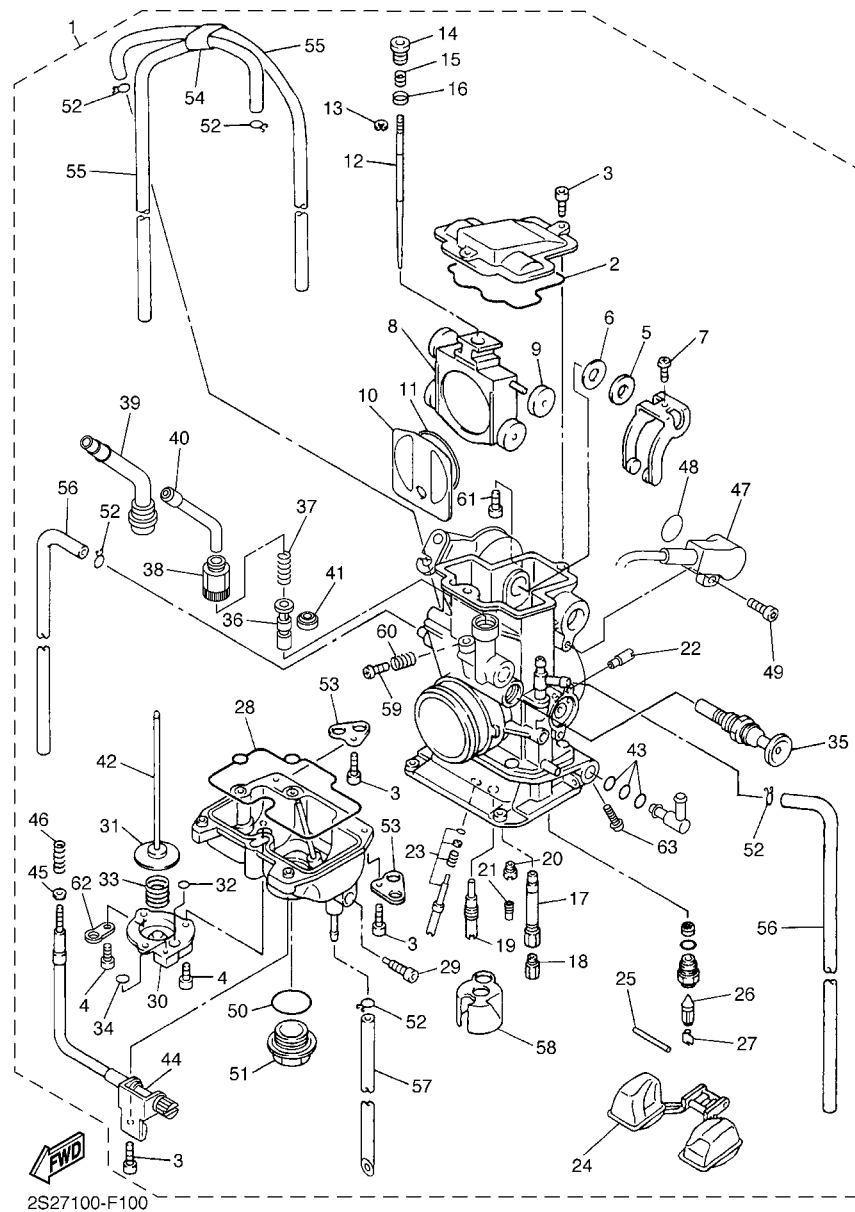

2S27100-F100

FIG. 10 CARBURETOR

REF. NO.	PART NO.	DESCRIPTION	5XCG	5XCH	5XCJ	5XCK	REMARKS
45	90201-08410	.WASHER, PLATE	1	1	1	1	
46	5TA-14934-00	.SPRING, THROTTLE STOP	1	1	1	1	
47	5XC-85885-00	.THROTTLE SENSOR ASSY	1	1	1	1	
48	5NX-14562-00	.O-RING	1	1	1	1	
49	5NX-14216-00	.SCREW	1	1	1	1	
50	4MX-14561-00	.O-RING	1	1	1	1	
51	4MX-14115-00	.PLUG, SCREW	1	1	1	1	
52	3TJ-14137-40	.CLIP	5	5	5	5	
53	5BE-14146-00	.PLATE	2	2	2	2	
54	5TA-14261-00	.HOLDER	1	1	1	1	
55	5UL-14196-00	.PIPE	2	2	2	2	
56	5TA-14197-00	.PIPE	2	2	2	2	
57	5TJ-14987-00	.HOSE	1	1	1	1	
58	5JG-14346-00	.PLATE	1	1	1	1	
59	5JG-14565-00	.SCREW	1	1	1	1	
60	5JG-14531-00	.SPRING, ADJUST SCREW	1	1	1	1	
61	5NL-14591-00	.SCREW	1	1	1	1	
62	5PA-14146-00	.PLATE	1	1	1	1	
63	5XD-14325-00	.SCREW, PAN HEAD	1	1	1	1	

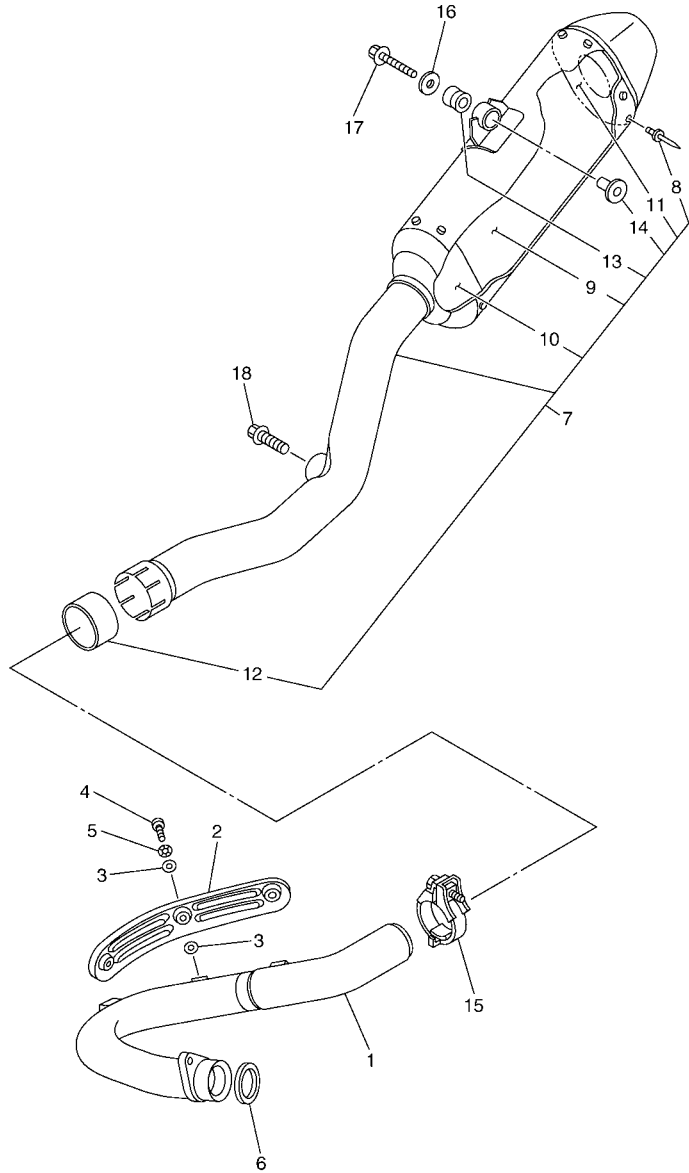

5XCG100-F110

FIG. 11 EXHAUST

REF. NO.	PART NO.	DESCRIPTION	5XCG	5XCH	5XCJ	5XCK	REMARKS
1	5XC-14611-20	PIPE, EXHAUST 1	1	1	1	1	
2	5XC-14628-00	PROTECTOR, EXHAUST PIPE	1	1	1	1	
3	4BD-14766-00	WASHER, PROTECTOR	6	6	6	6	
4	98980-06008	SCREW, BIND	3	3	3	3	
5	90206-06090	WASHER, WAVE	3	3	3	3	
6	5NL-14613-00	GASKET, EXHAUST PIPE	1	1	1	1	
7	5XC-14750-40	SILENCER ASSY				1	
8	90267-48084	.RIVET, BLIND	16	16	16	16	
9	5XC-1469A-10	.FIBER				1	
10	2S2-1469E-00	.FIBER	1	1	1	1	
11	2S2-1469F-00	.FIBER	1	1	1	1	
12	5XD-14714-00	.GASKET, MUFFLER	1	1	1	1	
13	5BE-14747-00	.DAMPER, MUFFLER	1	1	1	1	
14	90387-08081	.COLLAR	1	1	1	1	
15	5BE-14788-00	BAND, SILENCER	1	1	1	1	
16	90201-08061	WASHER, PLATE	1	1	1	1	
17	90105-08137	BOLT, FLANGE	1	1	1	1	
18	90105-08307	BOLT, FLANGE	1	1	1	1	

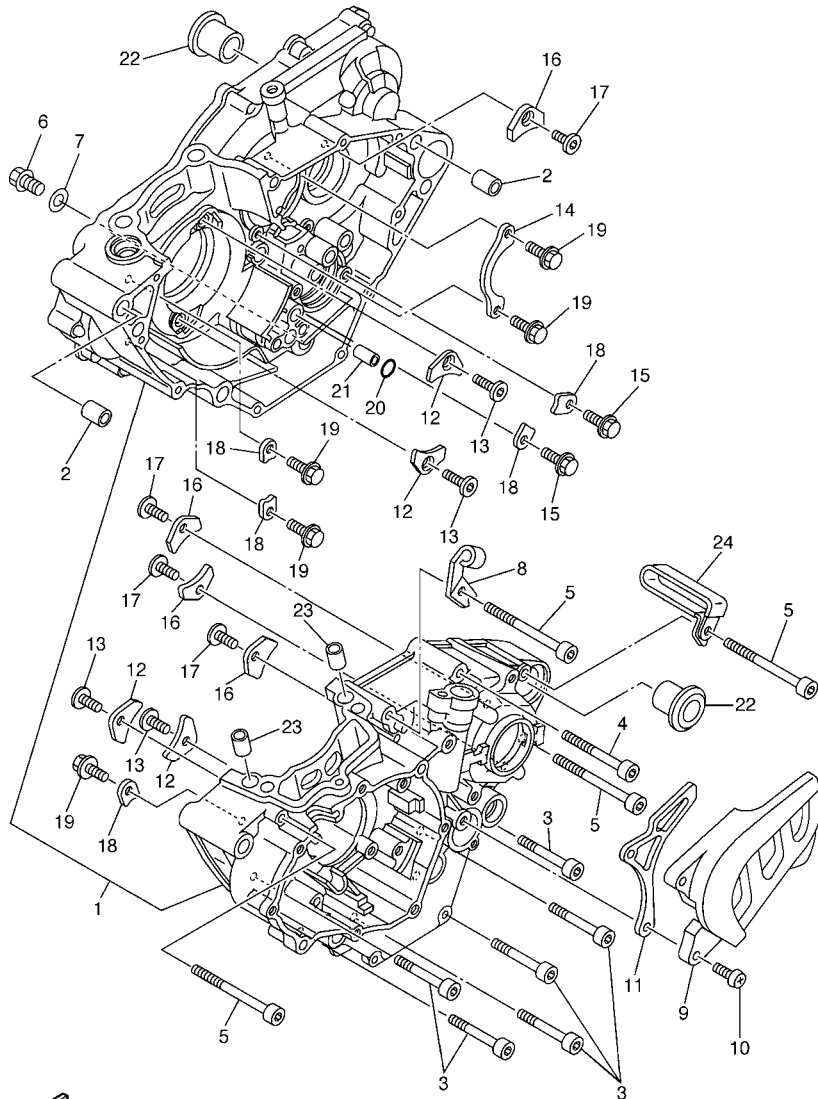

5XC9100-E120

FIG. 12 CRANKCASE

REF. NO.	PART NO.	DESCRIPTION	5XCG	5XCH	5XCJ	5XCK	REMARKS
1	5XC-15150-20-YX	CRANKCASE ASSY	1	1	1	1	
2	93612-16254	PIN, DOWEL	2	2	2	2	
3	91312-06045	BOLT	6	6	6	6	
4	91312-06055	BOLT	1	1	1	1	
5	91312-06070	BOLT	4	4	4	4	
6	95022-10016	BOLT, FLANGE	1	1	1	1	
7	90430-10188	GASKET	1	1	1	1	
8	5NL-15441-01	HOLDER, CLUTCH CABLE	1	1	1	1	
9	5BE-15421-10	COVER, CRANKCASE 2	1	1	1	1	
10	98502-06025	SCREW, PAN HEAD	2	2	2	2	
11	5NL-17466-00	GUIDE, CHAIN	1	1	1	1	
12	5BE-15383-01	PLATE, BEARING COVER	4	4	4	4	
13	90149-06085	SCREW	4	4	4	4	
14	5NL-15388-00	PLATE, BEARING COVER	1	1	1	1	
15	90105-06081	BOLT, FLANGE	2	2	2	2	
16	4JT-15381-01	PLATE, BEARING COVER	4	4	4	4	
17	90149-06074	SCREW	4	4	4	4	
18	5DH-18562-00	PLATE, STOPPER 2	5	5	5	5	
19	90105-06081	BOLT, FLANGE	5	5	5	5	
20	93210-10197	O-RING	1	1	1	1	
21	99530-10114	PIN, DOWEL	1	1	1	1	
22	90387-18007	COLLAR	2	2	2	2	
23	99530-10116	PIN, DOWEL	2	2	2	2	
24	90465-10013	CLAMP	1	1	1	1	

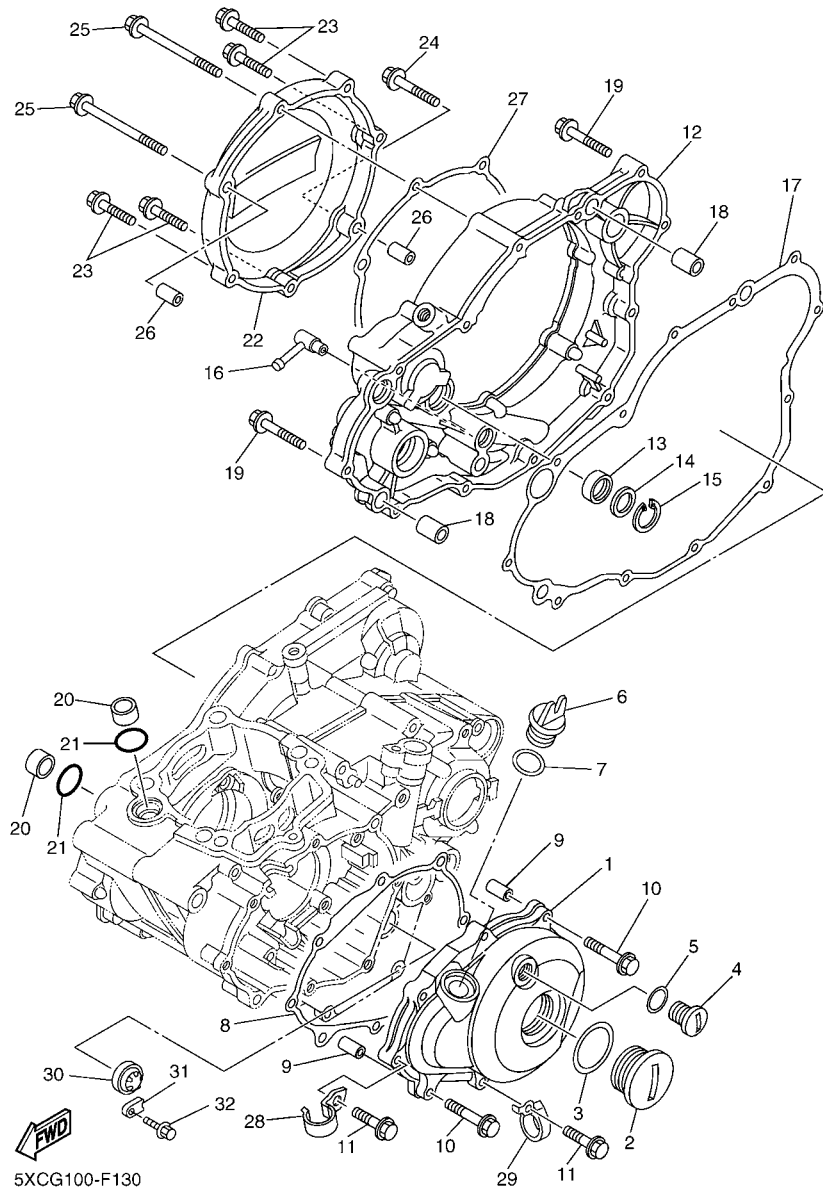
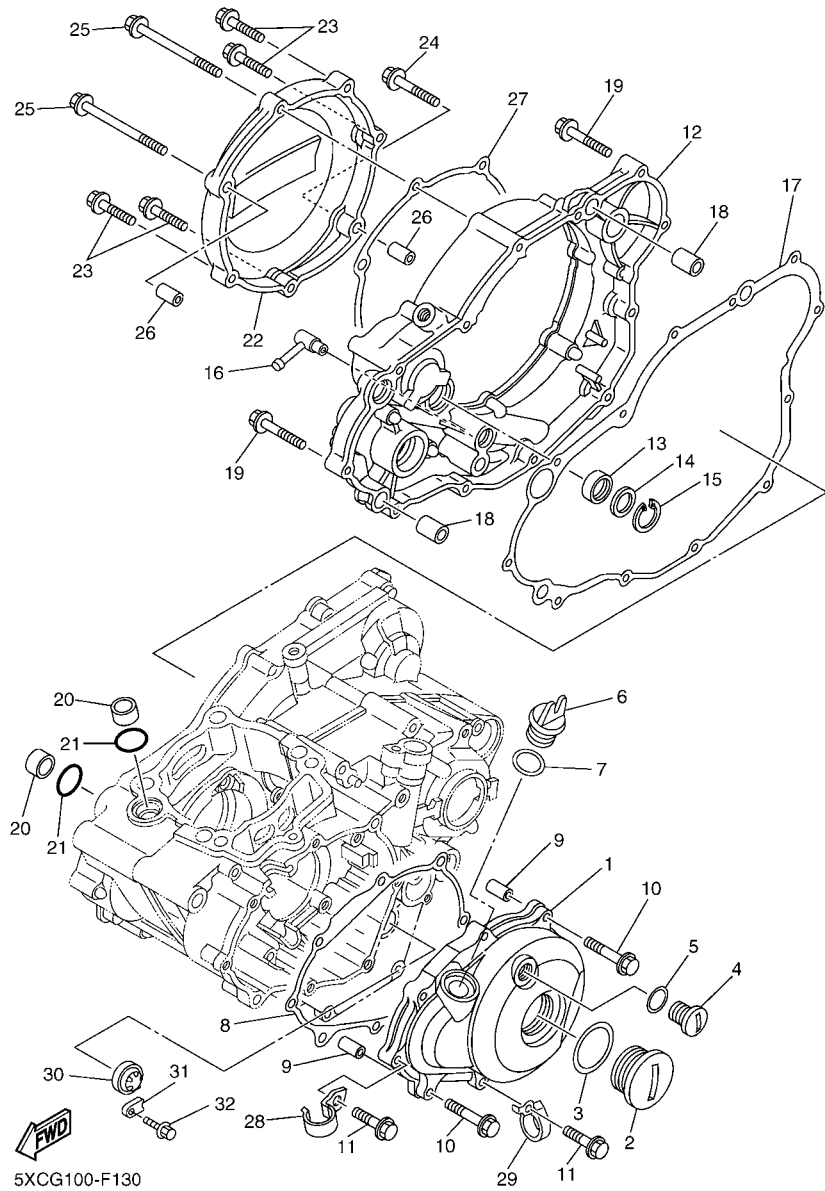

FIG. 13 CRANKCASE COVER 1

REF. NO.	PART NO.	DESCRIPTION	5XCG	5XCH	5XCJ	5XCK	REMARKS
1	5NL-15411-20	COVER, CRANKCASE 1	1	1	1	1	
2	90340-32123	PLUG, STRAIGHT SCREW	1	1	1	1	
3	93210-32172	O-RING	1	1	1	1	
4	90340-14128	PLUG, STRAIGHT SCREW	1	1	1	1	
5	93210-14369	O-RING	1	1	1	1	
6	3Y1-15363-00	PLUG, OIL	1	1	1	1	
7	93210-19123	O-RING	1	1	1	1	
8	5NL-15451-00	GASKET, CRANKCASE COVER 1	1	1	1	1	
9	99530-08016	PIN, DOWEL	2	2	2	2	
10	95022-06035	BOLT, FLANGE	2	2	2	2	
11	95022-06025	BOLT, FLANGE	6	6	6	6	
12	5XC-15431-01	COVER, CRANKCASE 3	1	1	1	1	
13	93101-14164	OIL SEAL	1	1	1	1	
14	90201-15701	WASHER, PLATE (T=1.0)	1	1	1	1	
15	99009-22500	CIRCLIP	1	1	1	1	
16	5XC-15373-00	PIPE, BREATHER	1	1	1	1	
17	5NL-15462-00	GASKET, CRANKCASE COVER 3	1	1	1	1	
18	91812-16001	PIN, DOWEL	2	2	2	2	
19	95022-06035	BOLT, FLANGE	8	8	8	8	
20	5NL-12564-00	PIPE, WATER	2	2	2	2	
21	93210-16716	O-RING	2	2	2	2	
22	5NL-15415-10	COVER, GENERATOR	1	1	1	1	
23	95022-06025	BOLT, FLANGE	4	4	4	4	
24	95022-06035	BOLT, FLANGE	1	1	1	1	
25	90105-06098	BOLT, FLANGE	2	2	2	2	
26	99530-08016	PIN, DOWEL	2	2	2	2	
27	5NL-15453-10	GASKET	1	1	1	1	



5XCG100-F130

FIG. 13 CRANKCASE COVER 1

REF. NO.	PART NO.	DESCRIPTION	5XCG	5XCH	5XCJ	5XCK	REMARKS
28	90465-08029	CLAMP	1	1	1	1	
29	2S2-15378-00	HOLDER	1	1	1	1	
30	3Y1-15361-00	GAUGE, LEVEL	1	1	1	1	
31	5XC-15118-00	HOLDER	1	1	1	1	
32	90105-06094	BOLT, FLANGE	1	1	1	1	

FIG. 14 STARTER

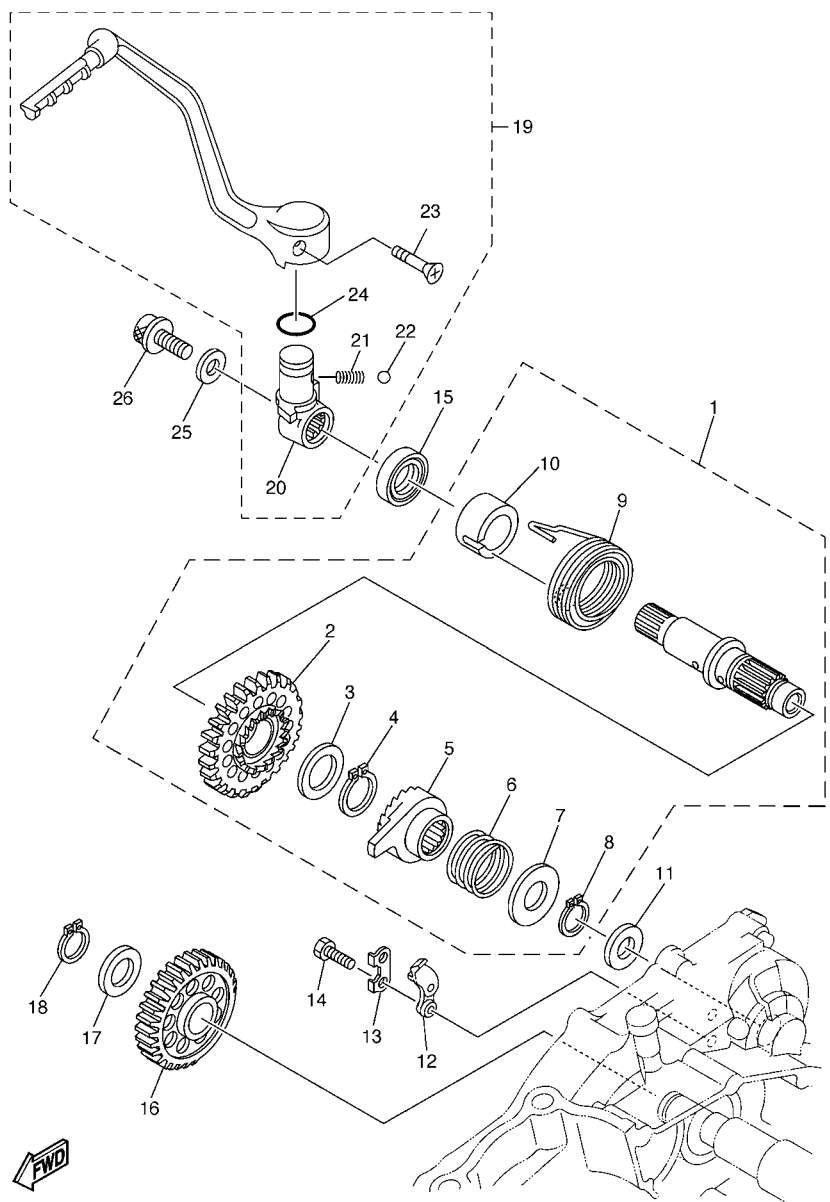

5XC9100-E140

REF. NO.	PART NO.	DESCRIPTION	5XCG	5XCH	5XCJ	5XCK	REMARKS
1	5NL-15601-20	KICK SHAFT ASSY	1	1	1	1	
2	5NL-15641-20	.GEAR, KICK	1	1	1	1	
3	90201-20685	.WASHER, PLATE (T=0.5)	1	1	1	1	
4	93410-20038	.CIRCLIP	1	1	1	1	
5	2S2-15671-00	.WHEEL, RATCHET	1	1	1	1	
6	90501-160A2	.SPRING, COMPRESSION	1	1	1	1	
7	90201-167P7	.WASHER, PLATE	1	1	1	1	
8	99009-16400	.CIRCLIP	1	1	1	1	
9	90508-30743	.SPRING, TORSION	1	1	1	1	
10	5NL-15664-00	.GUIDE, SPRING	1	1	1	1	
11	90201-162H4	WASHER, PLATE	1	1	1	1	
12	5SG-15668-00	STOPPER	1	1	1	1	
13	214-15686-00	WASHER, LOCK	1	1	1	1	
14	90101-06044	BOLT	2	2	2	2	
15	93102-18278	OIL SEAL	1	1	1	1	
16	5NL-15651-00	GEAR, KICK IDLE	1	1	1	1	
17	90201-177G4	WASHER, PLATE	1	1	1	1	
18	99009-17400	CIRCLIP	1	1	1	1	
19	5XC-15620-10	KICK CRANK ASSY	1	1	1	1	
20	5XC-15621-10	.BOSS, KICK CRANK	1	1	1	1	
21	90501-147A5	.SPRING, COMPRESSION	1	1	1	1	
22	93507-32009	.BALL	1	1	1	1	
23	90152-06010	.SCREW, COUNTERSUNK	1	1	1	1	
24	93210-17570	.O-RING	1	1	1	1	
25	90201-08048	WASHER, PLATE	1	1	1	1	
26	90110-08051	BOLT, HEXAGON SOCKET HEAD	1	1	1	1	

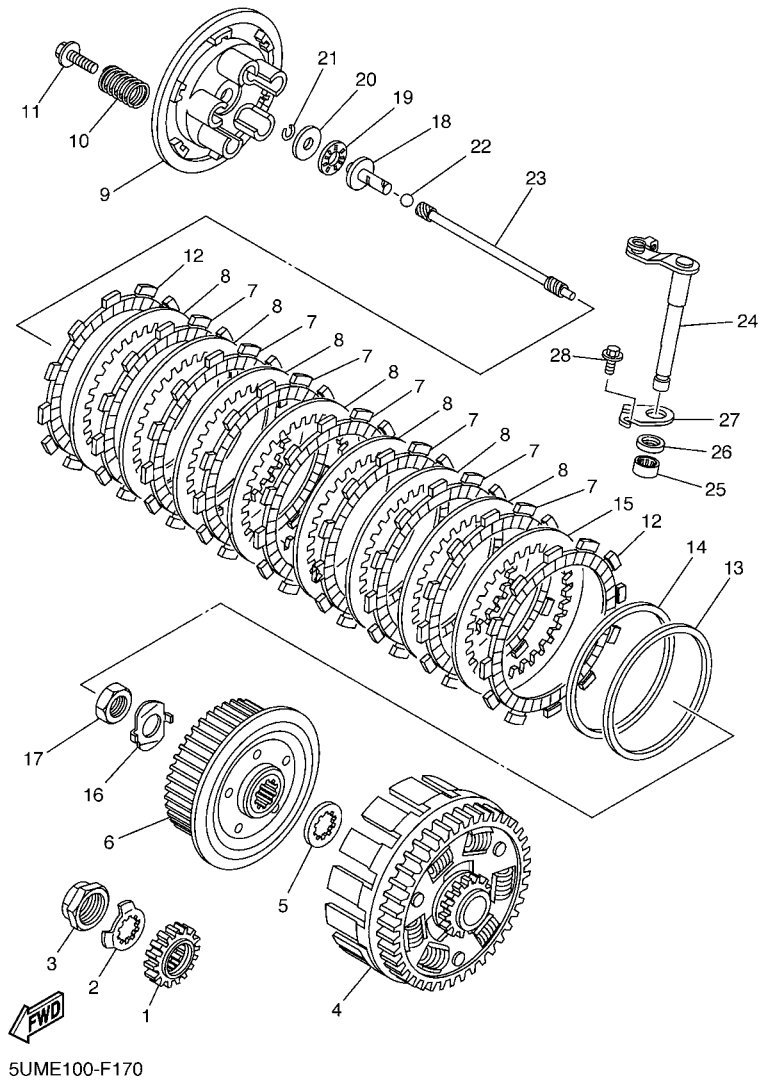

FIG. 15 CLUTCH

REF. NO.	PART NO.	DESCRIPTION	5XCG	5XCH	5XCJ	5XCK	REMARKS
1	5NL-16111-00	GEAR, PRIMARY DRIVE	1	1	1	1	
2	90215-20003	WASHER, LOCK	1	1	1	1	
3	90179-18001	NUT	1	1	1	1	
4	5NL-16150-10	PRIMARY DRIVEN GEAR COMP.	1	1	1	1	
5	5NL-16154-00	PLATE, THRUST 1	1	1	1	1	
6	5NL-16371-00	BOSS, CLUTCH	1	1	1	1	
7	5DH-16321-00	PLATE, FRICTION	7	7	7	7	
8	5NL-16325-00	PLATE, CLUTCH 2	7	7	7	7	
9	5HD-16351-00	PLATE, PRESSURE 1	1	1	1	1	
10	90501-224J9	SPRING, COMPRESSION	5	5	5	5	(PINK)
11	90159-06092	SCREW, WITH WASHER	5	5	5	5	
12	3XJ-16321-00	PLATE, FRICTION	2	2	2	2	
13	5NL-16384-00	PLATE, SEAT	1	1	1	1	
14	5NL-16383-10	SPRING, CLUTCH BOSS	1	1	1	1	
15	5NL-16325-10	PLATE, CLUTCH 2	1	1	1	1	
16	90215-16289	WASHER, LOCK	1	1	1	1	
17	90170-16326	NUT	1	1	1	1	
18	5NL-16356-00	ROD, PUSH 1	1	1	1	1	
19	93340-21008	BEARING	1	1	1	1	
20	90201-080H1	WASHER, PLATE	1	1	1	1	
21	93440-07182	CIRCLIP	1	1	1	1	
22	93511-32027	BALL	1	1	1	1	
23	5NL-16357-10	ROD, PUSH 2	1	1	1	1	
24	5JG-16381-10	PUSH LEVER COMP.	1	1	1	1	
25	93317-11287	BEARING	1	1	1	1	
26	93102-12224	OIL SEAL	1	1	1	1	
27	4JT-16384-00	PLATE, SEAT	1	1	1	1	

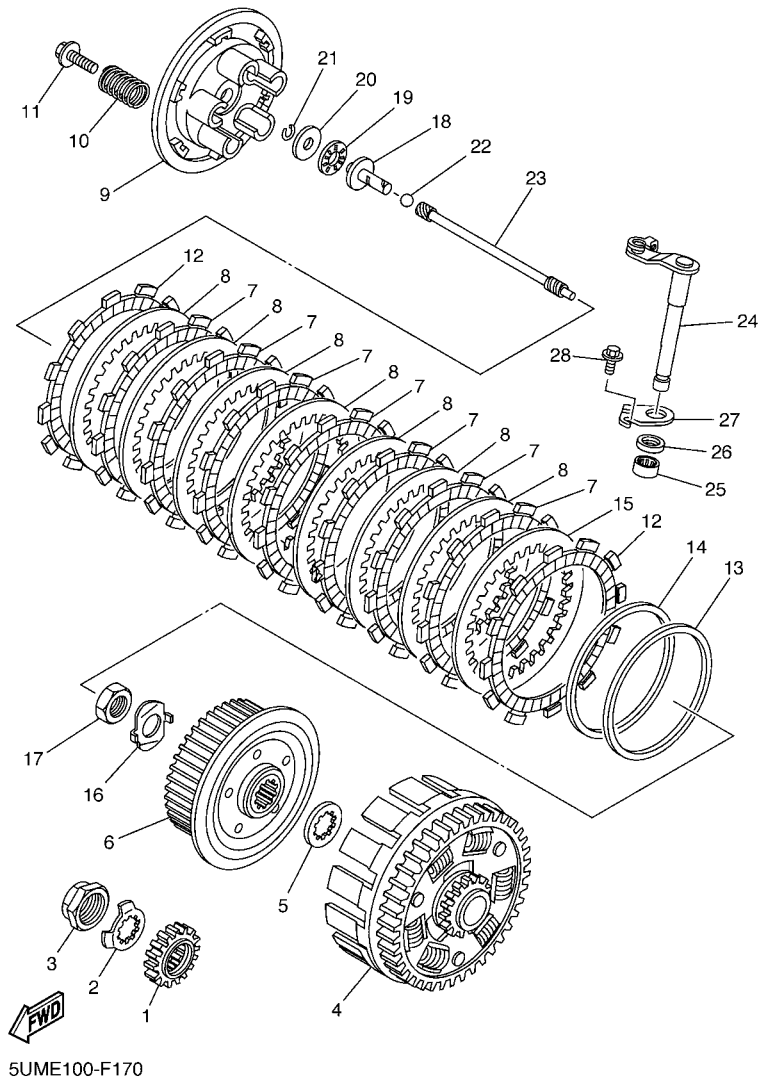
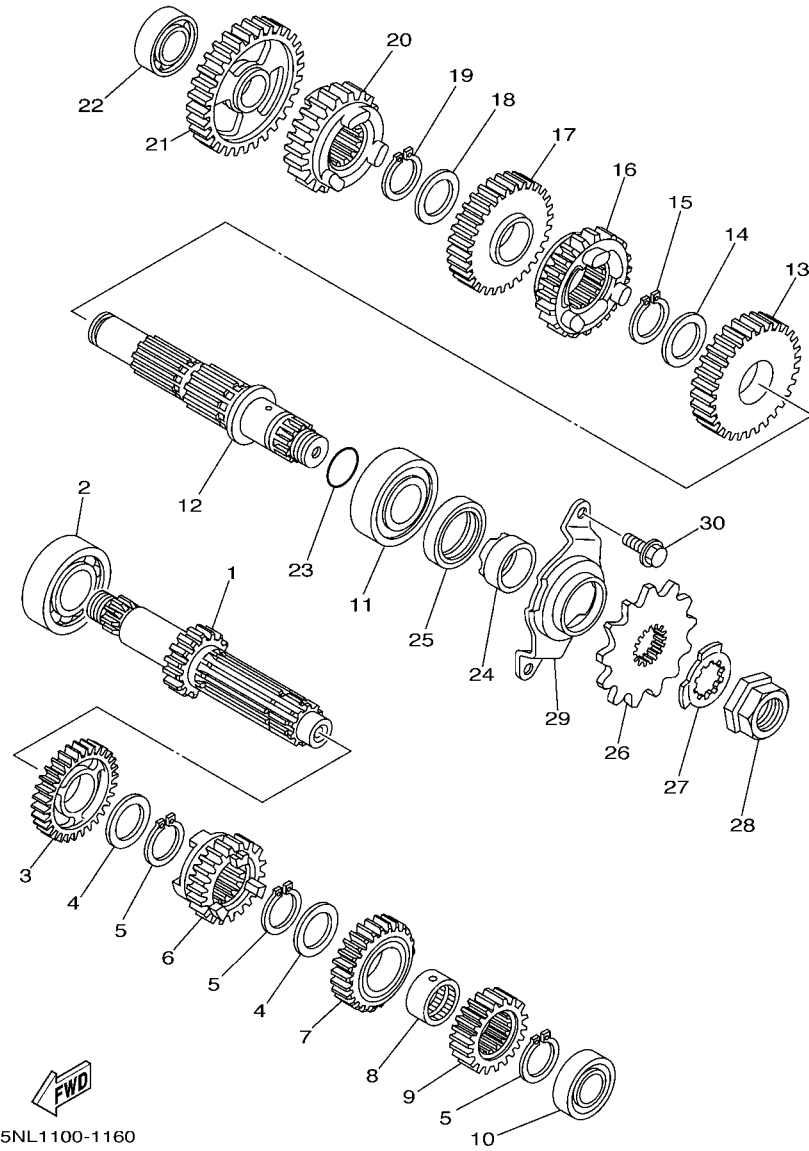

FIG. 15 CLUTCH

REF. NO.	PART NO.	DESCRIPTION	5XCG	5XCH	5XCJ	5XCK	REMARKS
28	95022-06010	BOLT, FLANGE	1	1	1	1	

FIG. 16 TRANSMISSION



5NL1100-1160

REF. NO.	PART NO.	DESCRIPTION	5XCG	5XCH	5XCJ	5XCK	REMARKS
1	5NL-17411-10	AXLE,MAIN (14T)	1	1	1	1	
2	93306-20447	BEARING	1	1	1	1	
3	5NL-17151-00	GEAR, 5TH PINION (24T)	1	1	1	1	
4	90209-20008	WASHER	2	2	2	2	
5	93410-22039	CIRCLIP	3	3	3	3	
6	5NL-17131-10	GEAR, 3RD PINION (20T)	1	1	1	1	
7	5NL-17141-11	GEAR, 4TH PINION (22T)	1	1	1	1	
8	90387-20006	COLLAR	1	1	1	1	
9	5NL-17121-00	GEAR, 2ND PINION (16T)	1	1	1	1	
10	93306-00320	BEARING	1	1	1	1	
11	93306-27208	BEARING	1	1	1	1	
12	5NL-17402-00	DRIVE AXLE ASSY	1	1	1	1	
13	5NL-17221-00	GEAR, 2ND WHEEL (28T)	1	1	1	1	
14	90209-23012	WASHER	1	1	1	1	
15	93410-26067	CIRCLIP	1	1	1	1	
16	5NL-17241-11	GEAR, 4TH WHEEL (27T)	1	1	1	1	
17	5NL-17231-11	GEAR, 3RD WHEEL (29T)	1	1	1	1	
18	90209-20008	WASHER	1	1	1	1	
19	93410-22039	CIRCLIP	1	1	1	1	
20	5NL-17251-10	GEAR, 5TH WHEEL (25T)	1	1	1	1	
21	5NL-17211-10	GEAR, 1ST WHEEL (30T)	1	1	1	1	
22	93306-00317	BEARING	1	1	1	1	
23	93210-196A4	O-RING	1	1	1	1	
24	90387-22001	COLLAR	1	1	1	1	
25	93102-28010	OIL SEAL	1	1	1	1	
26	9383B-13218	SPROCKET, DRIVE (13T)	1	1	1	1	
27	90215-20003	WASHER, LOCK	1	1	1	1	

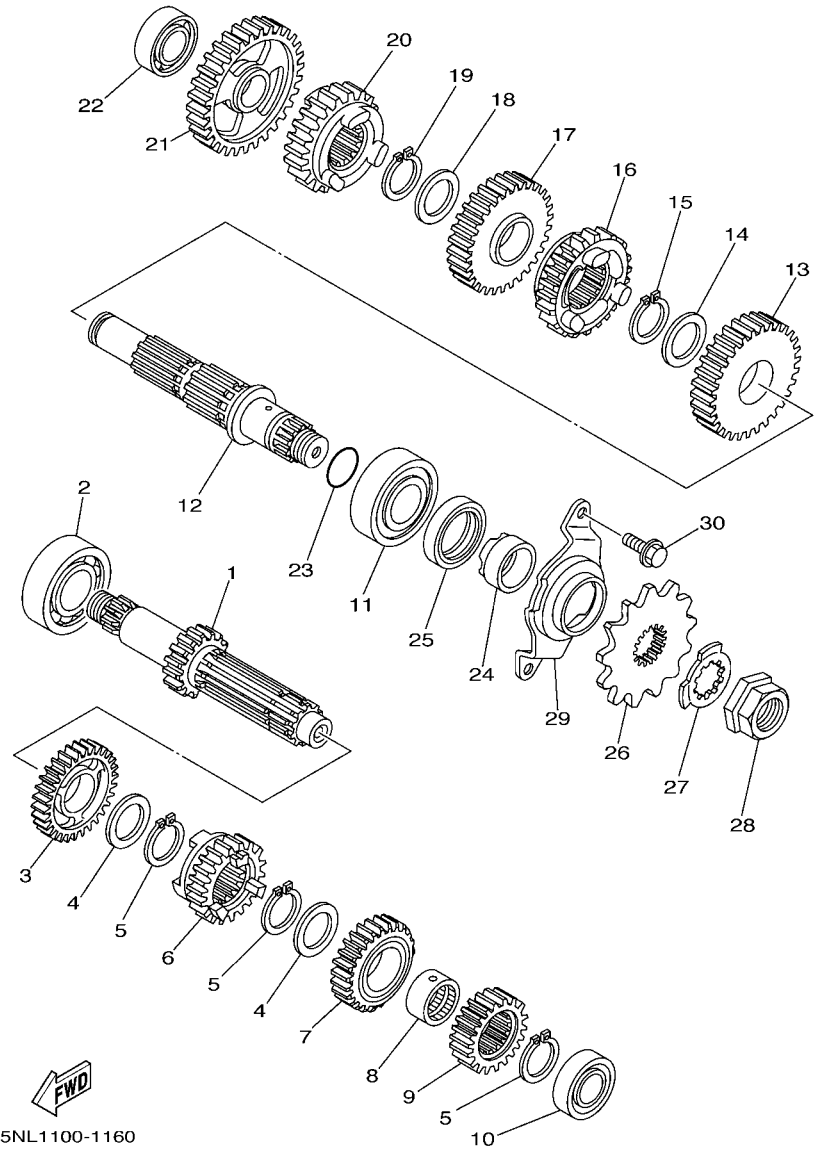
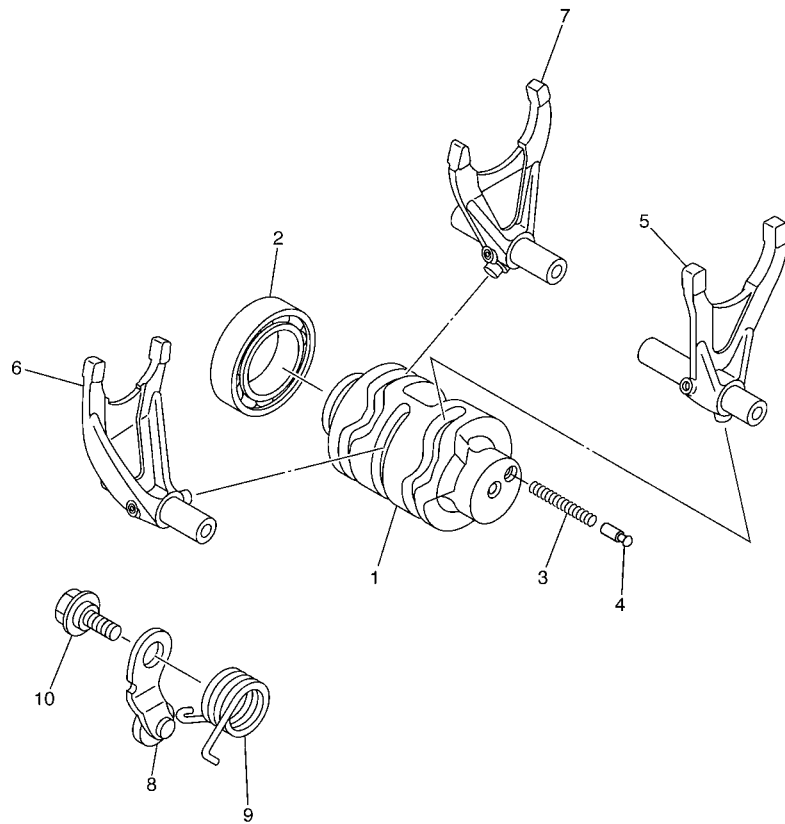

FIG. 16 TRANSMISSION

REF. NO.	PART NO.	DESCRIPTION	5XCG	5XCH	5XCJ	5XCK	REMARKS
28	90179-18001	NUT	1	1	1	1	
29	5NL-17471-10	PLATE, COVER	1	1	1	1	
30	90105-06081	BOLT, FLANGE	2	2	2	2	

FIG. 17 SHIFT CAM & FORK



REF. NO.	PART NO.	DESCRIPTION	5XCG	5XCH	5XCJ	5XCK	REMARKS
1	5NL-18541-00	CAM, SHIFT	1	1	1	1	
2	93306-90509	BEARING	1	1	1	1	
3	90501-06022	SPRING, COMPRESSION	1	1	1	1	
4	4UN-18542-00	POINT, NEUTRAL	1	1	1	1	
5	5NL-18501-00	FORK, SHIFT 1	1	1	1	1	
6	5NL-18502-00	FORK, SHIFT 2	1	1	1	1	
7	5NL-18503-00	FORK, SHIFT 3	1	1	1	1	
8	3XK-18140-00	STOPPER LEVER ASSY	1	1	1	1	
9	90508-26561	SPRING, TORSION	1	1	1	1	
10	90109-06193	BOLT	1	1	1	1	

5XC9100-E170

FIG. 18 SHIFT SHAFT

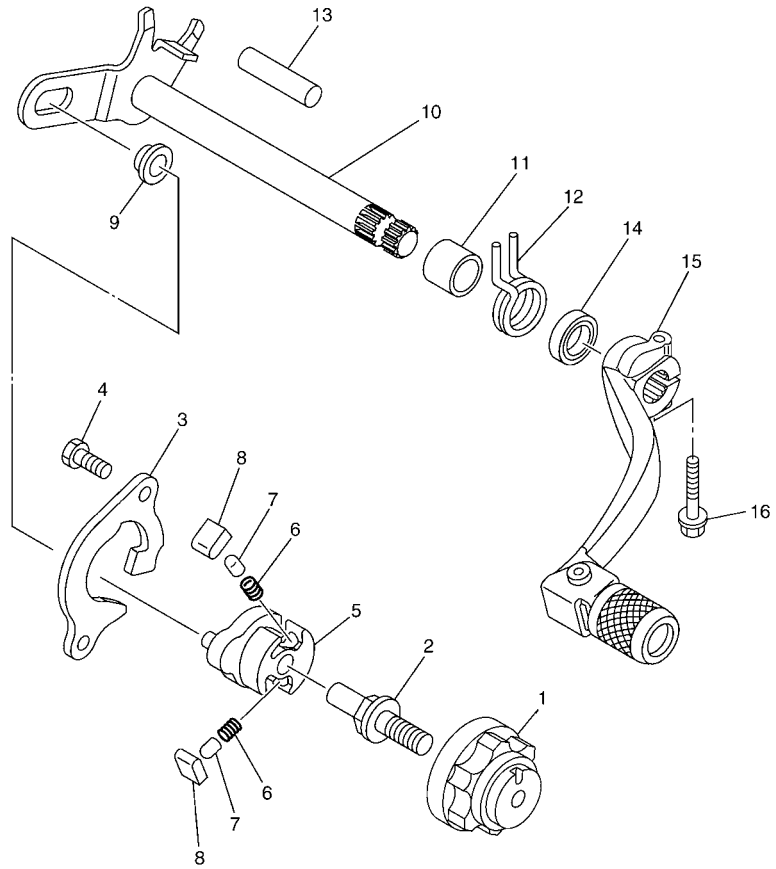

REF. NO.	PART NO.	DESCRIPTION	5XCG	5XCH	5XCJ	5XCK	REMARKS
1	2S2-18185-00	SEGMENT	1	1	1	1	
2	3XJ-18173-10	PIN, SHIFT	1	1	1	1	
3	5BE-18172-00	GUIDE, SHIFT	1	1	1	1	
4	90101-06041	BOLT	2	2	2	2	
5	5LP-18122-01	LEVER, SHIFT 2	1	1	1	1	
6	90501-052G5	SPRING, COMPRESSION	2	2	2	2	
7	3XJ-18184-00	PIN, PAWL	2	2	2	2	
8	3XJ-18182-00	PAWL, SHIFTER	2	2	2	2	
9	3XJ-18178-00	ROLLER, SHIFT LEVER	1	1	1	1	
10	5UL-18101-10	SHIFT SHAFT ASSY	1	1	1	1	
11	90387-124F4	COLLAR	1	1	1	1	
12	90508-291A8	SPRING, TORSION	1	1	1	1	
13	93608-33002	PIN, DOWEL	1	1	1	1	
14	93102-12224	OIL SEAL	1	1	1	1	
15	5XC-18110-00	SHIFT PEDAL ASSY	1	1	1	1	
16	95022-06020	BOLT, FLANGE	1	1	1	1	



5XCG100-F180

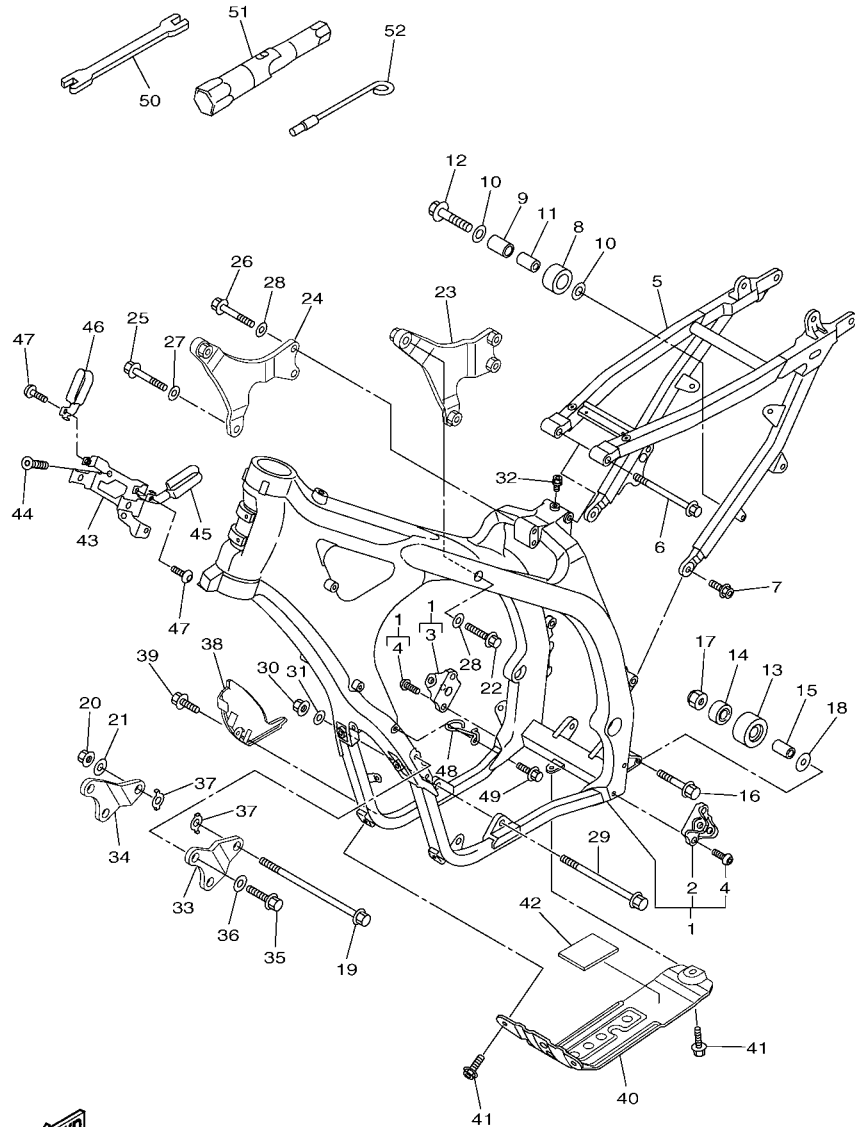

5XCG100-F190

FIG. 19 FRAME

REF. NO.	PART NO.	DESCRIPTION	5XCG	5XCH	5XCJ	5XCK	REMARKS
1	5XC-21101-G0	FRONT FRAME COMP.	1	1	1	1	
2	1C3-21447-10	.BRACKET, FOOTREST	1	1	1	1	
3	1C3-21448-10	.BRACKET, FOOTREST	1	1	1	1	
4	90149-10031	.SCREW	4	4	4	4	
5	2S2-21190-70	REAR FRAME COMP.	1	1	1	1	
6	90105-08156	BOLT, FLANGE	1	1	1	1	
7	90105-08307	BOLT, FLANGE	2	2	2	2	
8	30X-22178-00	TENSIONER	1	1	1	1	
9	4V4-22184-00	BUSH	1	1	1	1	
10	90201-08045	WASHER, PLATE	2	2	2	2	
11	90387-08041	COLLAR	1	1	1	1	
12	95022-08040	BOLT, FLANGE	1	1	1	1	
13	3JD-22178-20	TENSIONER	1	1	1	1	
14	93300-60839	BEARING	1	1	1	1	
15	90387-086N4	COLLAR	1	1	1	1	
16	90105-08146	BOLT, FLANGE	1	1	1	1	
17	90185-08009	NUT, SELF-LOCKING	1	1	1	1	
18	90201-08043	WASHER, PLATE	1	1	1	1	
19	90105-10174	BOLT, FLANGE	1	1	1	1	
20	90179-10658	NUT	1	1	1	1	
21	90201-10045	WASHER, PLATE	1	1	1	1	
22	90105-08150	BOLT, FLANGE	2	2	2	2	
23	5XC-21425-G0	BRACKET, REAR UPPER 1	1	1	1	1	
24	5XC-21426-G0	BRACKET, REAR UPPER 2	1	1	1	1	
25	90105-10191	BOLT, FLANGE	1	1	1	1	
26	90105-08147	BOLT, FLANGE	2	2	2	2	
27	90201-10045	WASHER, PLATE	1	1	1	1	

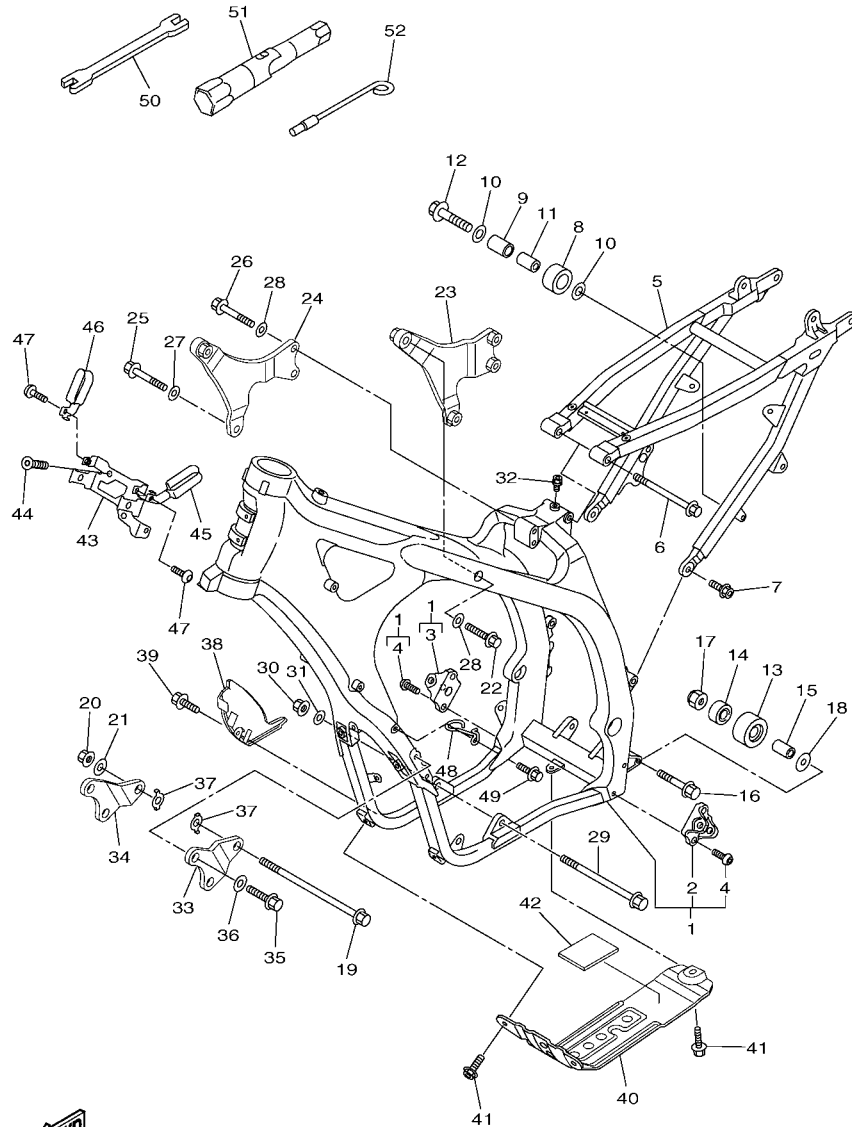

5XCG100-F190

FIG. 19 FRAME

REF. NO.	PART NO.	DESCRIPTION	5XCG	5XCH	5XCJ	5XCK	REMARKS
28	92902-08200	WASHER	4	4	4	4	
29	90105-10176	BOLT, FLANGE	1	1	1	1	
30	90179-10658	NUT	1	1	1	1	
31	90201-10045	WASHER, PLATE	1	1	1	1	
32	1C3-21244-10	NUT	1	1	1	1	
33	5XC-21417-G0	BRACKET, FRONT LOWER 1	1	1	1	1	
34	5XC-21418-G0	BRACKET, FRONT LOWER 2	1	1	1	1	
35	90105-08143	BOLT, FLANGE	4	4	4	4	
36	92902-08200	WASHER	4	4	4	4	
37	5XC-21456-90	PLATE, PATCH	2	2	2	2	
38	5XC-21471-90	PROTECTOR, ENGINE	1	1	1	1	
39	90119-06146	BOLT, WITH WASHER	1	1	1	1	
40	5XC-2147E-G0	GUARD, ENGINE 2	1	1	1	1	
41	90119-06146	BOLT, WITH WASHER	3	3	3	3	
42	5XC-21486-90	DAMPER 2	1	1	1	1	
43	5XC-21274-90	BRACKET, C.D.I. UNIT	1	1	1	1	
44	90151-06032	SCREW, COUNTERSUNK	2	2	2	2	
45	5XC-21163-90	HOLDER, CLUTCH CABLE	1	1	1	1	
46	5XC-21164-90	HOLDER, CABLE	1	1	1	1	
47	92012-05008	BOLT, BUTTON HEAD	2	2	2	2	
48	5XC-21288-90	GUIDE, CABLE	1	1	1	1	
49	90105-05014	BOLT, FLANGE	1	1	1	1	
50	5ET-28166-10	WRENCH, HEXAGON	1	1	1	1	
51	5TA-2814F-00	BOX, SPARK PLUG	1	1	1	1	
52	5XC-28116-00	TOOL, SPECIAL	1	1	1	1	

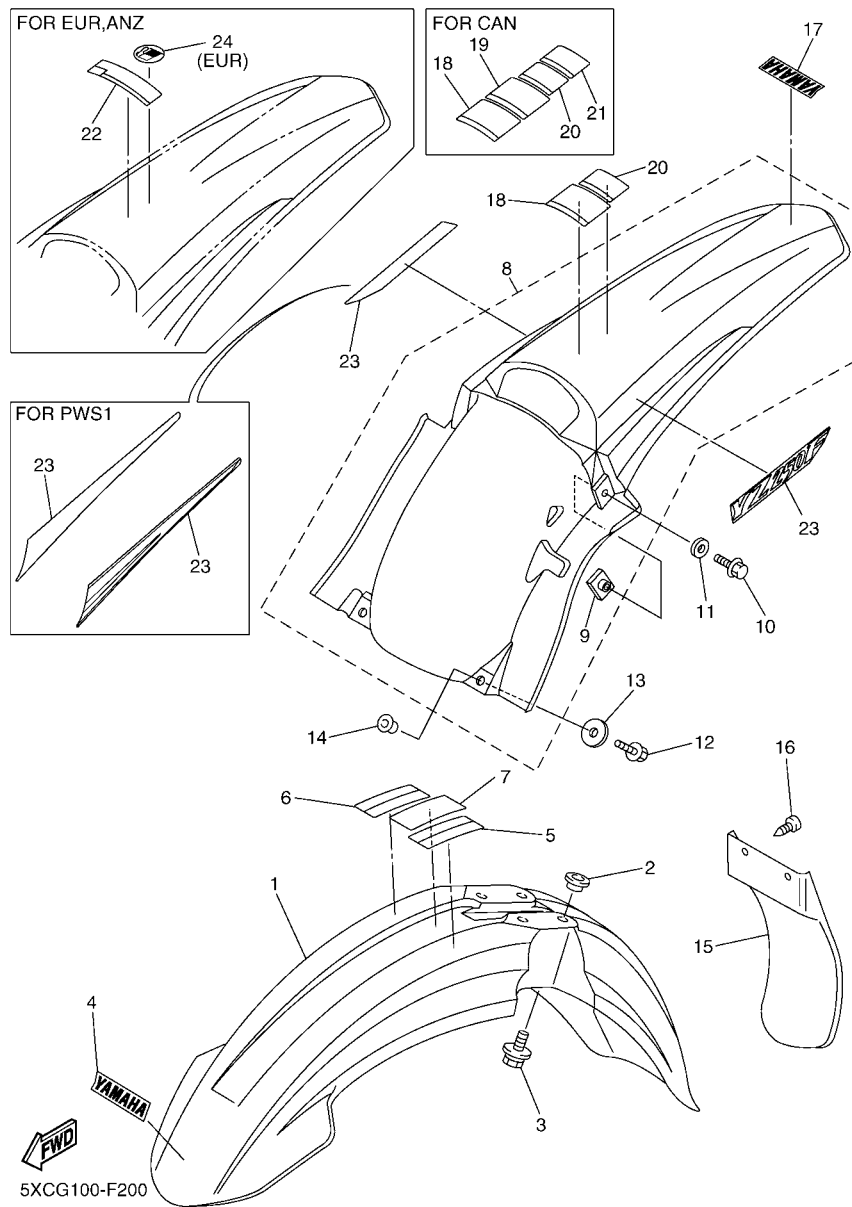

FIG. 20 FENDER

REF. NO.	PART NO.	DESCRIPTION	5XCG	5XCH	5XCJ	5XCK	REMARKS
1	1C3-21511-51	FENDER, FRONT	1	1	1	1	UR FOR DPBSE
	2S2-21511-70	FENDER, FRONT	1	1	1	1	UR FOR PWS1
2	90387-06090	COLLAR	4	4	4	4	
3	90119-06147	BOLT, WITH WASHER	4	4	4	4	
4	4ES-2153E-01	EMBLEM, YAMAHA	1	1	1	1	UR FOR DPBSE
	4ES-2153E-20	EMBLEM, YAMAHA	1	1	1	1	UR FOR PWS1
5	N/A						
6	N/A						
7	N/A						
8	5XC-21610-90	REAR FENDER COMP.	1	1	1	1	UR FOR DPBSE
	2S2-21610-70	REAR FENDER COMP.	1	1	1	1	UR FOR PWS1
9	5XE-21635-10	.NUT, REAR FENDER	2	2	2	2	
10	90105-06100	BOLT, FLANGE	2	2	2	2	
11	90201-06032	WASHER, PLATE	2	2	2	2	
12	90105-06106	BOLT, FLANGE	2	2	2	2	
13	90201-06571	WASHER, PLATE	2	2	2	2	
14	90387-06009	COLLAR	2	2	2	2	
15	5TA-21642-00	GUARD, FLAP	1	1	1	1	
16	97702-60016	SCREW, TAPPING	2	2	2	2	
17	5XC-2153E-00	EMBLEM, YAMAHA	1	1	1	1	UR FOR DPBSE
	5XC-2153E-10	EMBLEM, YAMAHA	1	1	1	1	UR FOR PWS1
18	N/A						
19	N/A						
20	N/A						

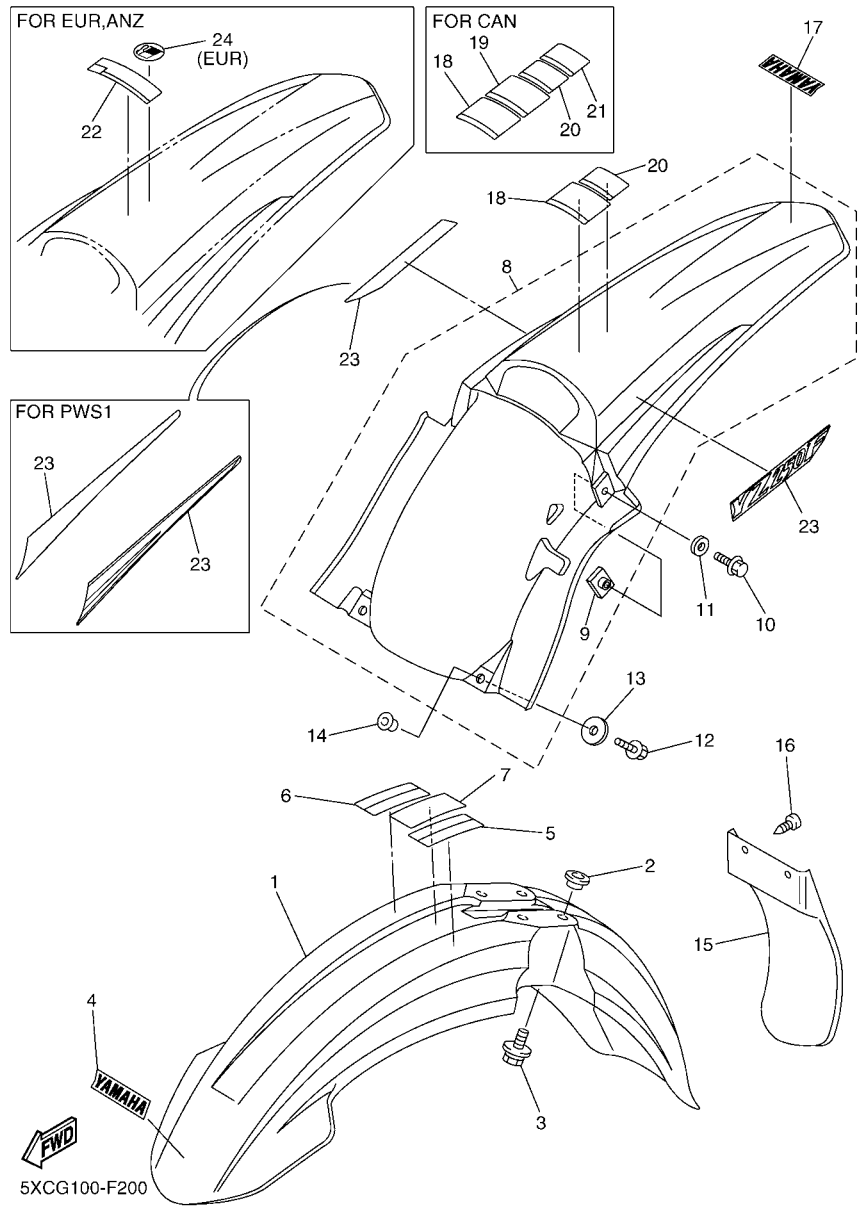

FIG. 20 FENDER

REF. NO.	PART NO.	DESCRIPTION	5XCG	5XCH	5XCJ	5XCK	REMARK/AS
21	N/A						
22	5PA-21568-00	LABEL, WARNING		1		1	
23	5XC-2163G-10	EMBLEM 1	2	2	2	2	UR FOR DPBSE
	2S2-2165A-00	GRAPHIC SET, REAR FENDER	1	1	1	1	UR FOR PWS1
24	N/A						

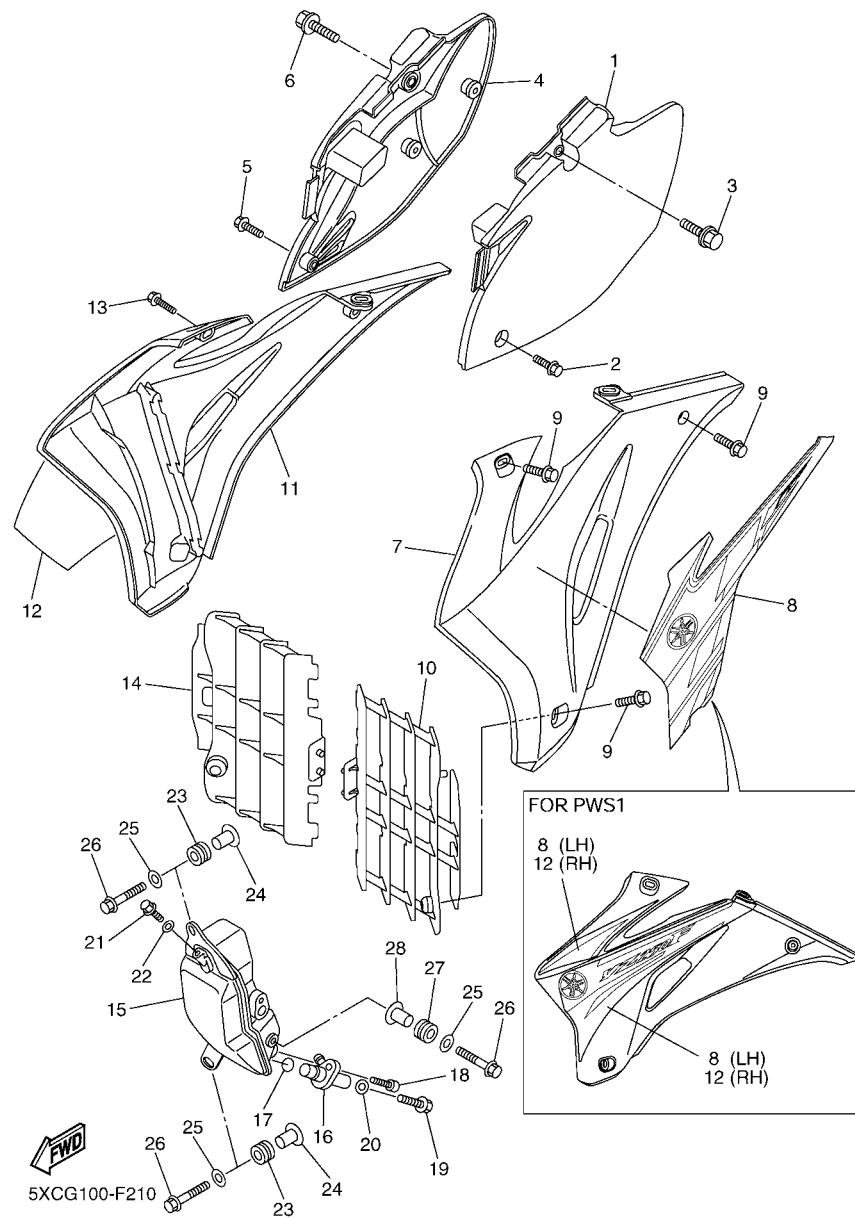

FIG. 21 SIDE COVER & OIL TANK

REF. NO.	PART NO.	DESCRIPTION	5XCG	5XCH	5XCJ	5XCK	REMARKS
1	5XC-21710-90	SIDE COVER ASSY 1	1	1	1	1	
2	90105-06103	BOLT, FLANGE	1	1	1	1	
3	90119-08095	BOLT, WITH WASHER	1	1	1	1	
4	5XC-21720-90	SIDE COVER ASSY 2	1	1	1	1	
5	90105-06103	BOLT, FLANGE	1	1	1	1	
6	90119-08095	BOLT, WITH WASHER	1	1	1	1	
7	5XC-21730-90	SIDE COVER ASSY 3	1	1	1	1	UR FOR DPBSE
	2S2-21730-70	SIDE COVER ASSY 3	1	1	1	1	UR FOR PWS1
8	5XC-2173E-10	GRAPHIC 1	1	1	1	1	UR FOR DPBSE
	5XC-2173L-10	GRAPHIC SET 1	1	1	1	1	UR FOR PWS1
9	90105-06064	BOLT, FLANGE	4	4	4	4	
10	2S2-2172A-70	PANEL 1	1	1	1	1	
11	5XC-21740-90	SIDE COVER ASSY 4	1	1	1	1	UR FOR DPBSE
	2S2-21740-70	SIDE COVER ASSY 4	1	1	1	1	UR FOR PWS1
12	5XC-2173F-10	GRAPHIC 2	1	1	1	1	UR FOR DPBSE
	5XC-2174L-10	GRAPHIC SET 2	1	1	1	1	UR FOR PWS1
13	90105-06064	BOLT, FLANGE	4	4	4	4	
14	2S2-2172A-80	PANEL 1	1	1	1	1	
15	5XC-21751-G0	TANK, OIL	1	1	1	1	
16	5XC-13416-90	PIPE, OIL 1	1	1	1	1	
17	93210-14369	O-RING	1	1	1	1	
18	91312-06016	BOLT	1	1	1	1	
19	90105-08151	BOLT, FLANGE	1	1	1	1	
20	90201-082A6	WASHER, PLATE	1	1	1	1	
21	90105-06128	BOLT, FLANGE	1	1	1	1	
22	90201-06630	WASHER, PLATE	1	1	1	1	
23	90480-10289	GROMMET	2	2	2	2	

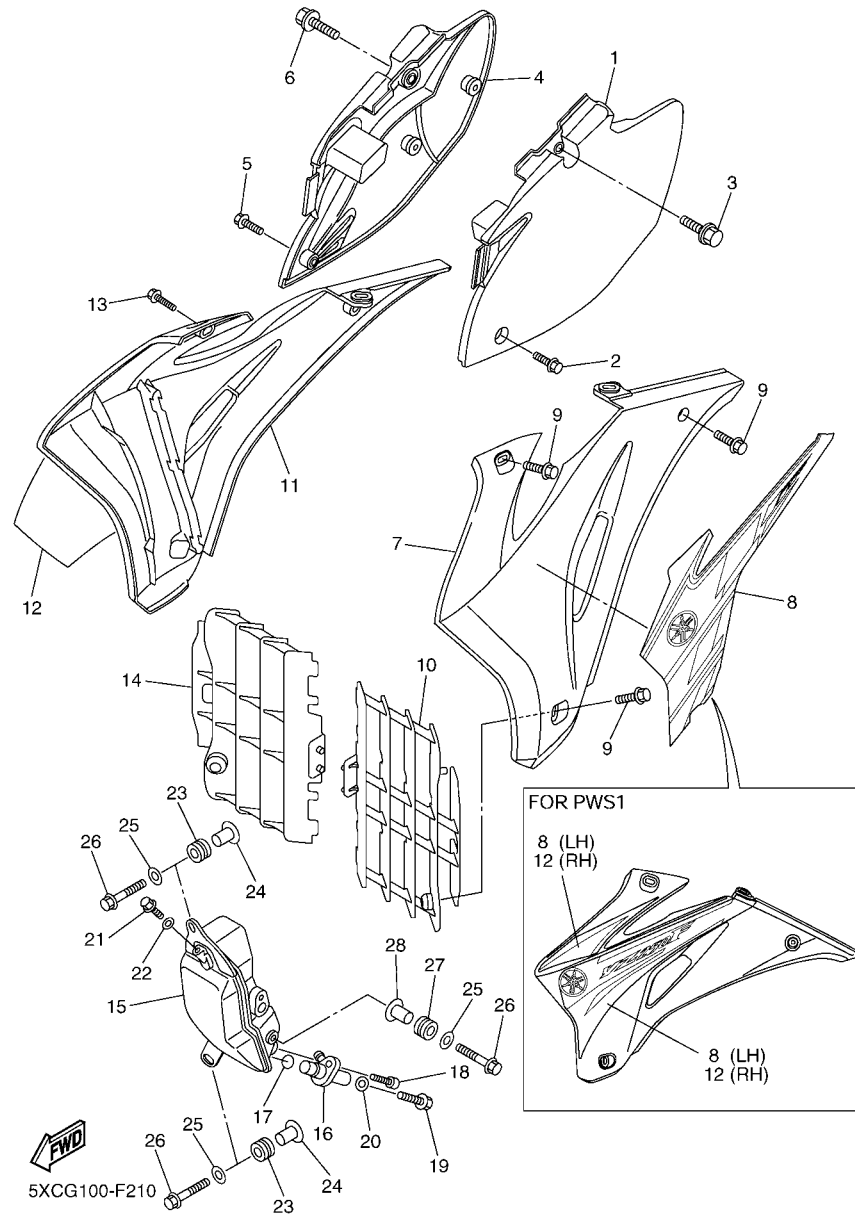
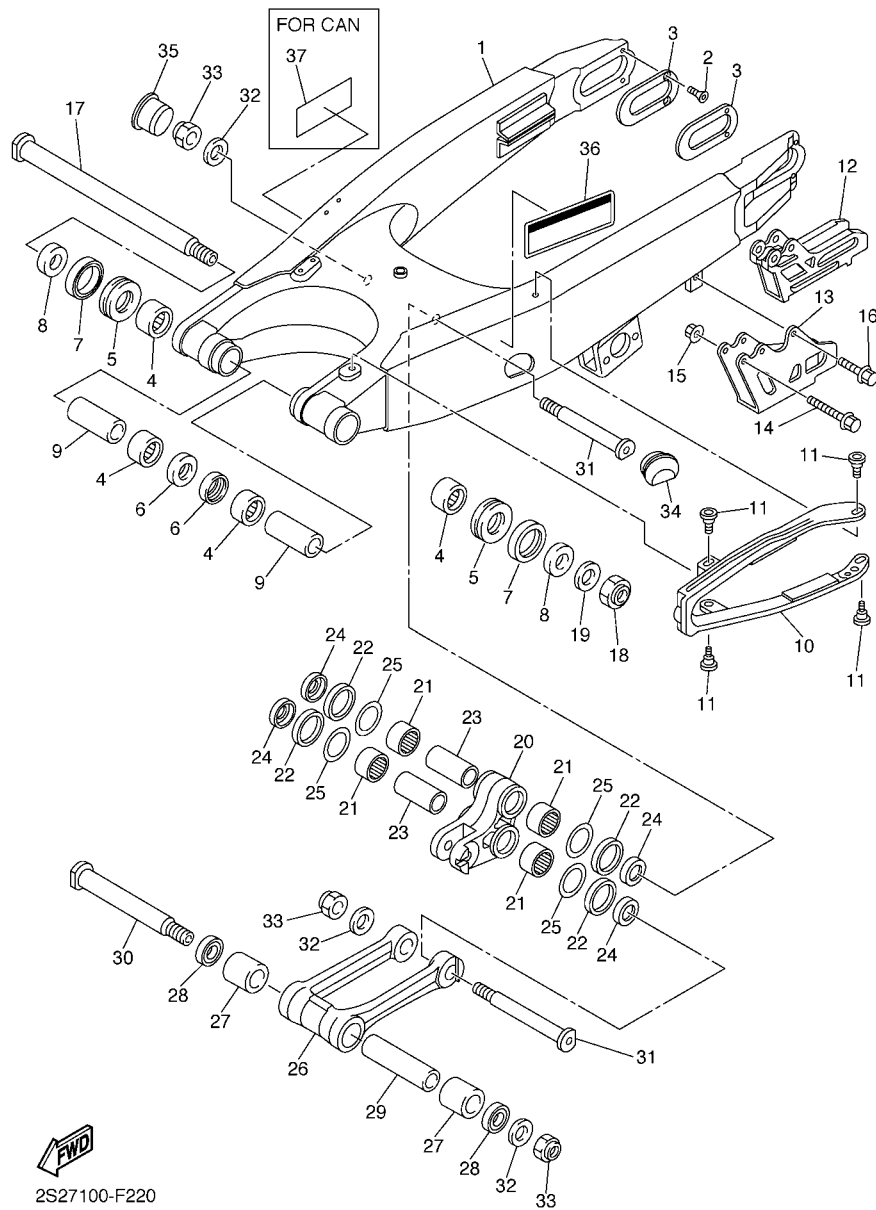

FIG. 21 SIDE COVER & OIL TANK

REF. NO.	PART NO.	DESCRIPTION	5XCG	5XCH	5XCJ	5XCK	REMARKS
24	90387-06150	COLLAR	2	2	2	2	
25	90201-06571	WASHER, PLATE	3	3	3	3	
26	90105-06112	BOLT, FLANGE	3	3	3	3	
27	90480-14433	GROMMET	1	1	1	1	
28	90387-06161	COLLAR	1	1	1	1	



2S27100-F220

FIG. 22 REAR ARM

REF. NO.	PART NO.	DESCRIPTION	5XCG	5XCH	5XCJ	5XCK	REMARKS
1	2S2-22110-70	REAR ARM COMP.	1	1	1	1	
2	90151-04003	SCREW, COUNTERSUNK	4	4	4	4	
3	1C3-22355-00	PATCH	2	2	2	2	
4	93317-22262	BEARING	4	4	4	4	
5	93342-22217	BEARING	2	2	2	2	
6	93106-22002	OIL SEAL	2	2	2	2	
7	93109-28043	OIL SEAL	2	2	2	2	
8	90387-18012	COLLAR	2	2	2	2	
9	90387-18004	COLLAR	2	2	2	2	
10	2S2-22151-70	SEAL, GUARD	1	1	1	1	
11	1C3-22969-90	SCREW, 1	4	4	4	4	
12	2S2-22199-70	SUPPORT, CHAIN	1	1	1	1	
13	2S2-22128-70	COVER, THRUST 1	1	1	1	1	
14	90105-06104	BOLT, FLANGE	2	2	2	2	
15	90179-06028	NUT	2	2	2	2	
16	90105-06105	BOLT, FLANGE	1	1	1	1	
17	1C3-22141-10	SHAFT, PIVOT	1	1	1	1	
18	90185-16002	NUT, SELF-LOCKING	1	1	1	1	
19	90201-16018	WASHER, PLATE	1	1	1	1	
20	5XC-2217A-G0	ARM, RELAY	1	1	1	1	
21	93315-32166	BEARING	4	4	4	4	
22	93109-25001	OIL SEAL	4	4	4	4	
23	90387-16010	COLLAR	2	2	2	2	
24	90209-16011	WASHER	4	4	4	4	
25	90201-21014	WASHER, PLATE	4	4	4	4	
26	5XC-2217F-G0	ROD, CONNECTING 1	1	1	1	1	
27	93315-32166	BEARING	2	2	2	2	

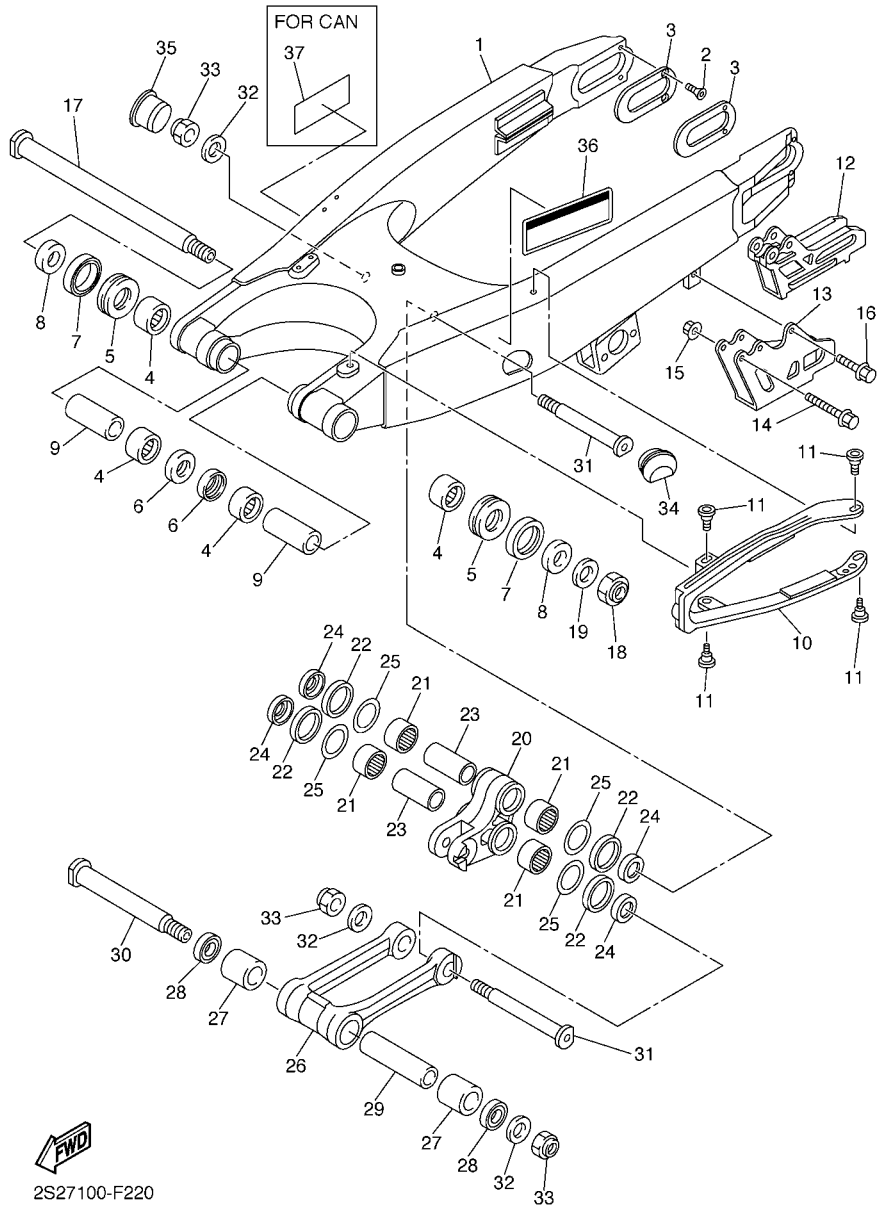

FWD
2S27100-F220

FIG. 22 REAR ARM

REF. NO.	PART NO.	DESCRIPTION	5XCG	5XCH	5XCJ	5XCK	REMARKS
28	93109-21001	OIL SEAL	2	2	2	2	
29	90387-14005	COLLAR	1	1	1	1	
30	5XC-22121-91	SHAFT 1	1	1	1	1	
31	1C3-22122-00	SHAFT 2	2	2	2	2	
32	90201-14020	WASHER, PLATE	3	3	3	3	
33	90185-14010	NUT, SELF-LOCKING	3	3	3	3	
34	1C3-2135F-00	COVER	1	1	1	1	
35	1C3-2139R-00	COVER 2	1	1	1	1	
36	3RV-21668-A0	LABEL, TIRE	1	1		1	
37	N/A						

FIG. 23 REAR SUSPENSION

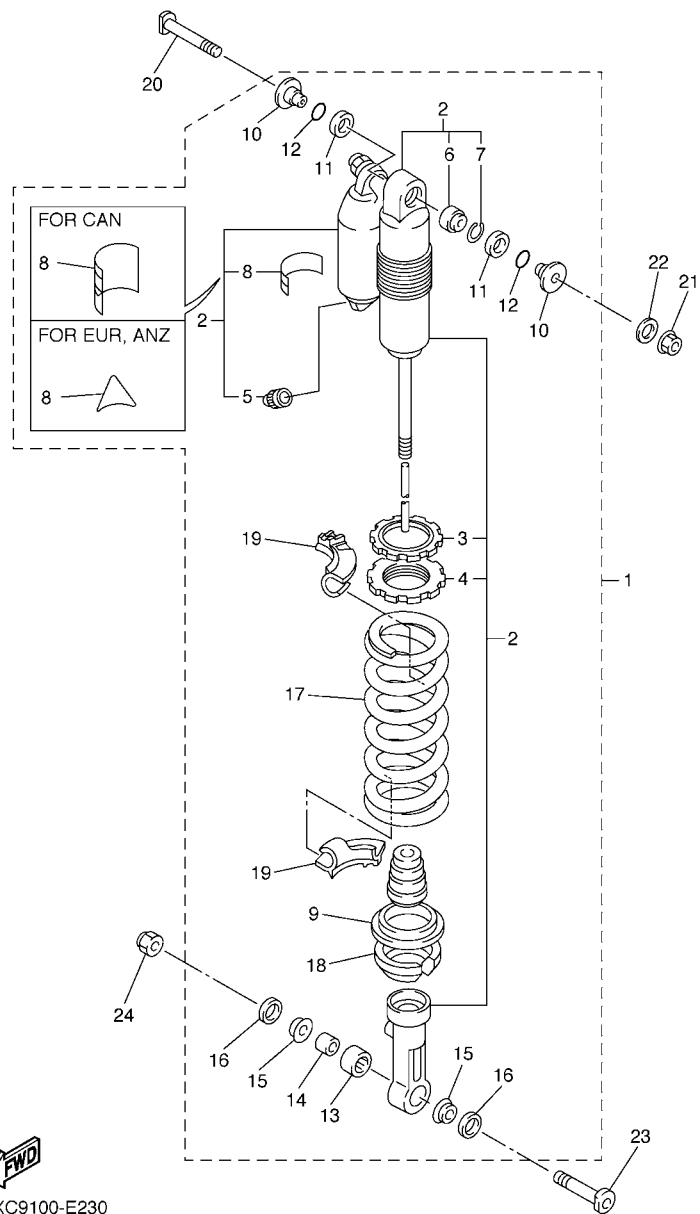

FWD
5XC9100-E230

REF. NO.	PART NO.	DESCRIPTION	5XCG	5XCH	5XCJ	5XCK	REMARKS
1	5XC-22200-K0	SHOCK ABSORBER ASSY, REAR				1	
2	5XC-22201-G0	.DAMPER SUB ASSY	1		1	1	
3	3SP-22234-00	..GUIDE, SPRING 3	1	1	1	1	
4	1C3-22213-L0	..SEAT, SPRING UPPER	1	1	1	1	
5	509-23184-L0	..CAP, AIR VALVE	1	1	1	1	
6	4JX-22226-00	..BUSH, SHOCK ABSORBER LOWER	1	1	1	1	
7	5DH-23183-00	..CIRCLIP	1	1	1	1	
8	4AA-22259-40	..LABEL, WARNING				1	
9	5MV-22224-00	.GUIDE, SPRING 2	1	1	1	1	
10	1C3-22253-50	.COLLAR, DISTANCE	2	2	2	2	
11	3JE-22475-00	.SEAL, DUST	2	2	2	2	
12	4EW-22474-00	.SEAL, RING	2	2	2	2	
13	5UN-22176-00	.BEARING	1	1	1	1	
14	5MV-22184-00	.BUSH	1	1	1	1	
15	1C3-22253-L0	.COLLAR, DISTANCE	2	2	2	2	
16	5NY-22475-00	.SEAL, DUST	2	2	2	2	
17	1C3-22212-20	.SPRING (K=48N/MM)	1	1	1	1	
18	1C3-22214-50	.GUIDE, SPRING 1	1	1	1	1	
19	1C3-22565-00	.SPRING SEAT	2	2	2	2	

FIG. 23 REAR SUSPENSION

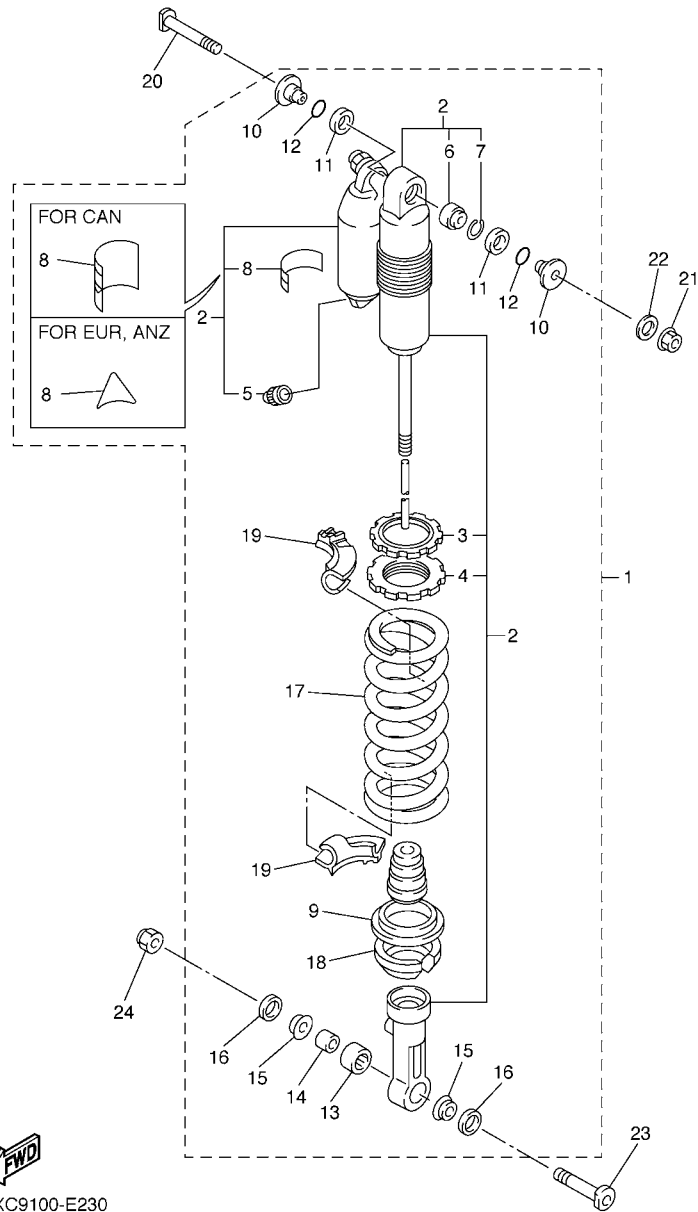

5XC9100-E230

REF. NO.	PART NO.	DESCRIPTION	5XCG	5XCH	5XCJ	5XCK	REMARKS
20	5XE-22242-00	BOLT 2	1	1	1	1	
21	95602-10200	NUT, U FLANGE	1	1	1	1	
22	92902-10200	WASHER	1	1	1	1	
23	5NY-22241-00	BOLT 1	1	1	1	1	
24	90185-10012	NUT, SELF-LOCKING	1	1	1	1	

D10

FIG. 24 STEERING

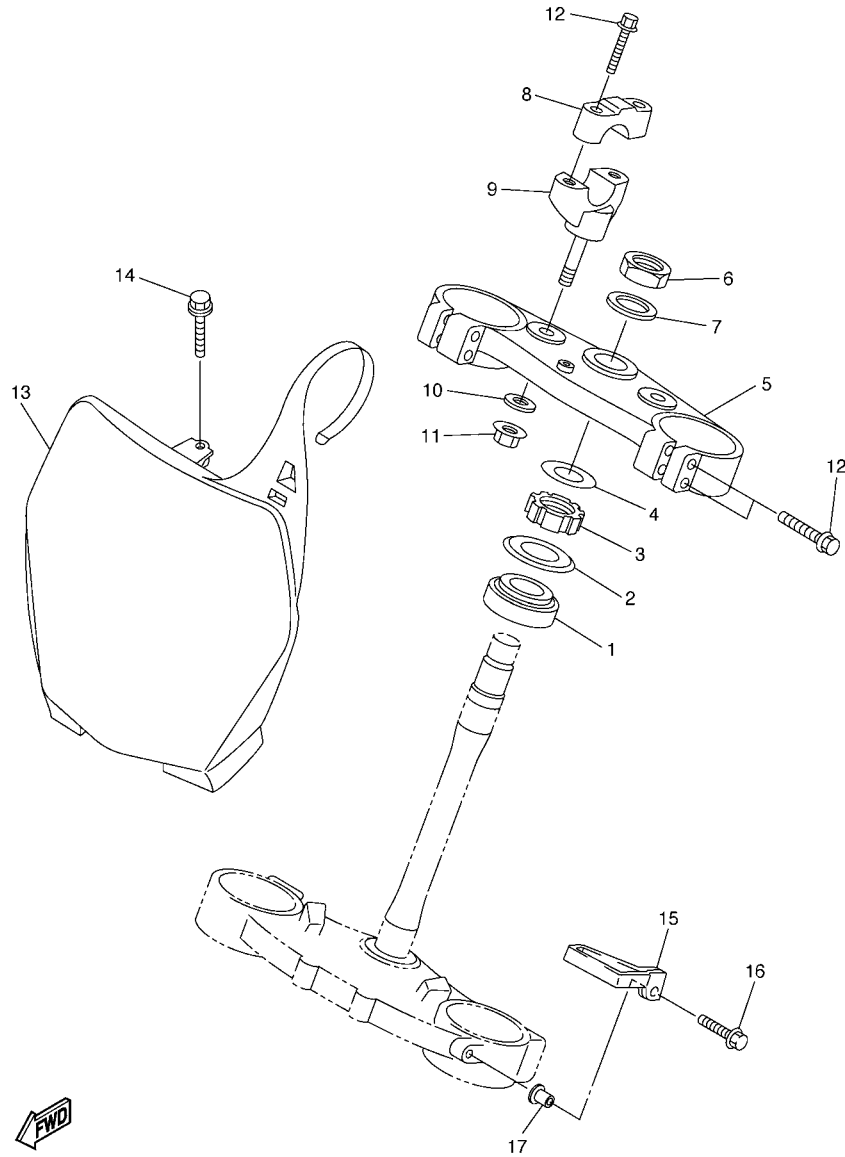

5XC9100-E240

REF. NO.	PART NO.	DESCRIPTION	5XCG	5XCH	5XCJ	5XCK	REMARKS
1	93332-00068	BEARING	1	1	1	1	
2	4EW-23416-00	COVER, BALL RACE 2	1	1	1	1	
3	90179-28003	NUT	1	1	1	1	
4	90201-286K9	WASHER, PLATE	1	1	1	1	
5	2S2-23435-70	CROWN, HANDLE	1	1	1	1	
6	90170-24003	NUT	1	1	1	1	
7	90201-24016	WASHER, PLATE	1	1	1	1	
8	5XC-23441-90	HOLDER, HANDLE UPPER	2	2	2	2	
9	2S2-23442-70	HOLDER, HANDLE LOWER	2	2	2	2	
10	92902-10200	WASHER	2	2	2	2	
11	95602-10200	NUT, U FLANGE	2	2	2	2	
12	90105-08154	BOLT, FLANGE	8	8	8	8	
13	1C3-23485-80	PLATE, NUMBER	1	1	1	1	
14	90119-06151	BOLT, WITH WASHER	1	1	1	1	
15	5XE-23389-00	GUIDE, CABLE	1	1	1	1	
16	90105-06107	BOLT, FLANGE	1	1	1	1	
17	90387-06104	COLLAR	1	1	1	1	

FIG. 25 FRONT FORK

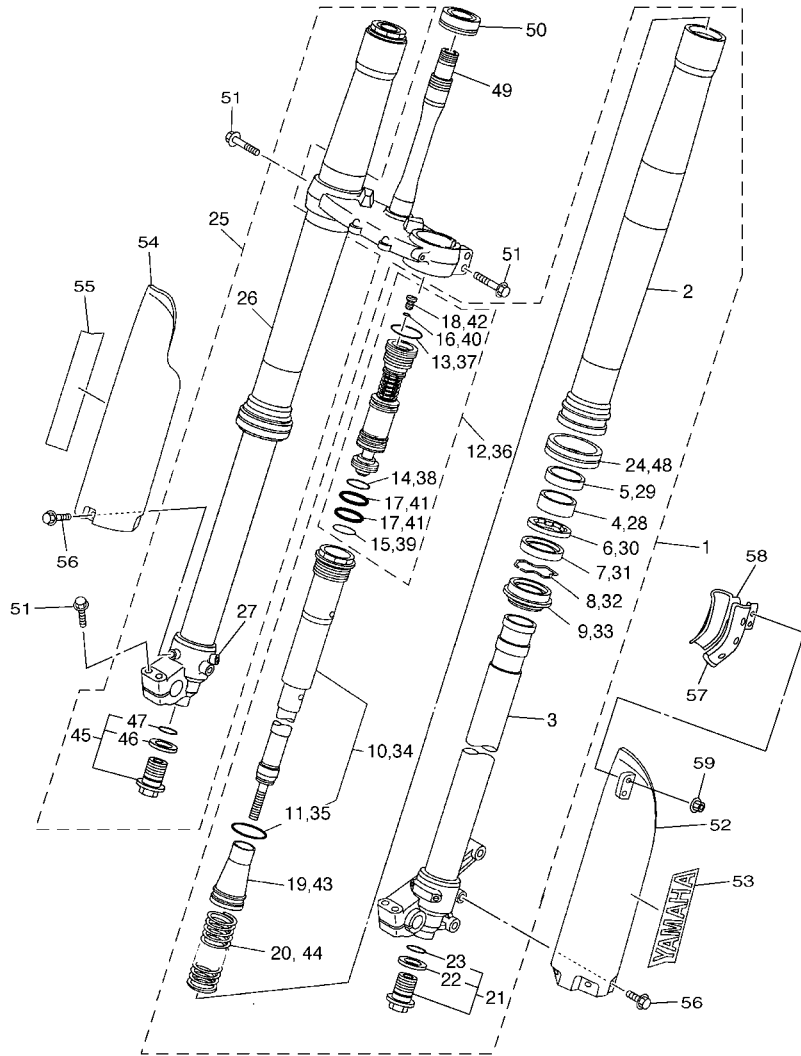

REF. NO.	PART NO.	DESCRIPTION	5XCG	5XCH	5XCJ	5XCK	REMARKS
1	5XC-23102-G0	FRONT FORK ASSY (L.H)	1		1	1	
2	1C3-23136-N0	.TUBE, OUTER (RIGHT)	1	1	1	1	
3	5XC-23120-M0	.INNER TUBE COMP.2	1	1	1	1	
4	5XE-23171-L0	.PISTON, FRONT FORK	1	1	1	1	
5	5XE-23125-L0	.METAL, SLIDE 1	1	1	1	1	
6	5XE-23146-L0	.WASHER, OIL SEAL	1	1	1	1	
7	1C3-23145-M0	.OIL SEAL	1	1	1	1	
8	5XE-23153-L0	.RING, SNAP	1	1	1	1	
9	5XE-23144-L0	.SEAL, DUST	1	1	1	1	
10	5XC-23170-M0	.CYLINDER COMP., FRONT FORK	1		1	1	
11	1C3-23147-L0	..O-RING	1	1	1	1	
12	5XC-2316A-R0	.VALVE COMP.	1		1	1	
13	1C3-23188-L0	..O-RING	1	1	1	1	
14	1C3-23188-N0	..O-RING	1	1	1	1	
15	1C3-23188-P0	..O-RING	1	1	1	1	
16	1C3-23188-R0	..O-RING	1	1	1	1	
17	1AE-23147-00	..O-RING	2	2	2	2	
18	1C3-23190-L0	.AIR VALVE COMP.	1	1	1	1	
19	1C3-23142-L0	.SEAT, SPRING UPPER	1	1	1	1	
20	1P8-23141-M1	.SPRING, FRONT FORK(K=4.2N/MM)	1	1	1	1	
21	1C3-23111-L1	.BOLT, CAP	1	1	1	1	
22	2HH-23158-L0	..GASKET	1	1	1	1	
23	276-23114-00	..GASKET	1	1	1	1	
24	1C3-2314F-M0	.PROTECTOR GUIDE COMP., 1	1	1	1	1	



5XCG100-F250

FIG. 25 FRONT FORK

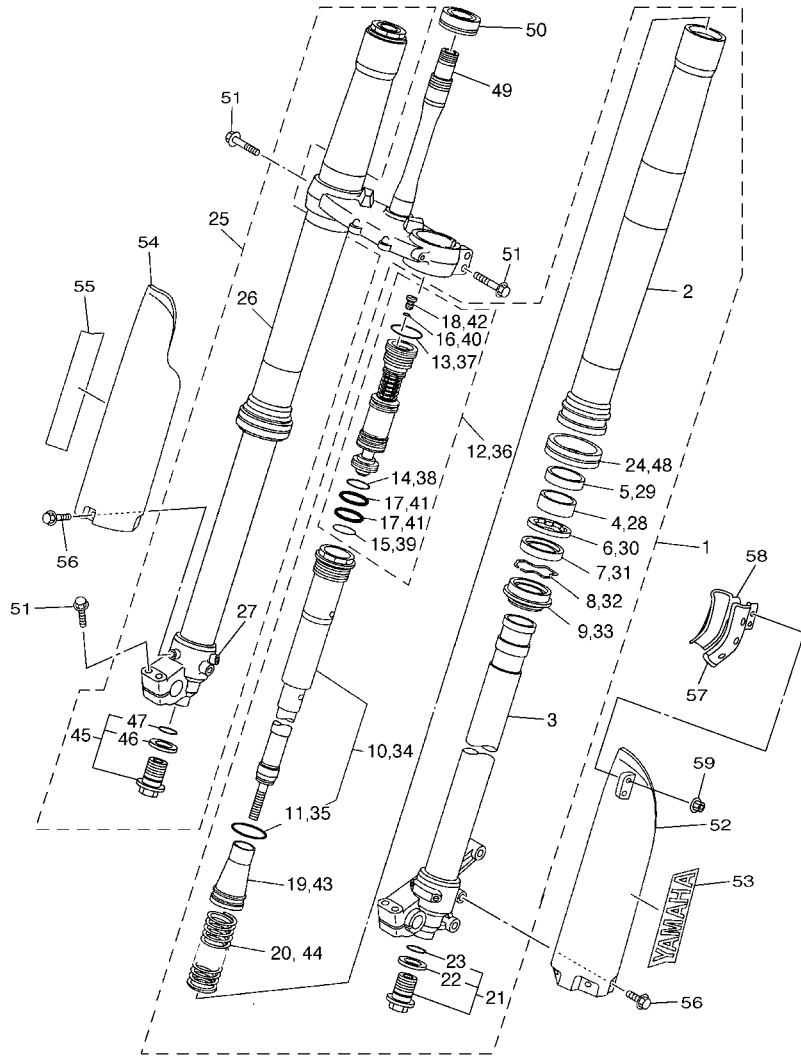

REF. NO.	PART NO.	DESCRIPTION	5XCG	5XCH	5XCJ	5XCK	REMARKS
25	5XC-23103-G0	FRONT FORK ASSY (R.H)	1		1	1	
26	1C3-23136-N0	.TUBE, OUTER (RIGHT)	1	1	1	1	
27	5XC-23110-M0	.INNER TUBE COMP.1	1	1	1	1	
28	5XE-23171-L0	.PISTON, FRONT FORK	1	1	1	1	
29	5XE-23125-L0	.METAL, SLIDE 1	1	1	1	1	
30	5XE-23146-L0	.WASHER, OIL SEAL	1	1	1	1	
31	1C3-23145-M0	.OIL SEAL	1	1	1	1	
32	5XE-23153-L0	.RING, SNAP	1	1	1	1	
33	5XE-23144-L0	.SEAL, DUST	1	1	1	1	
34	5XC-23170-M0	.CYLINDER COMP., FRONT FORK	1		1	1	
35	1C3-23147-L0	..O-RING	1	1	1	1	
36	5XC-2316A-R0	.VALVE COMP.	1		1	1	
37	1C3-23188-L0	..O-RING	1	1	1	1	
38	1C3-23188-N0	..O-RING	1	1	1	1	
39	1C3-23188-P0	..O-RING	1	1	1	1	
40	1C3-23188-R0	..O-RING	1	1	1	1	
41	1AE-23147-00	..O-RING	2	2	2	2	
42	1C3-23190-L0	.AIR VALVE COMP.	1	1	1	1	
43	1C3-23142-L0	.SEAT, SPRING UPPER	1	1	1	1	
44	1P8-23141-M1	.SPRING, FRONT FORK(K=4.2N/MM)	1	1	1	1	
45	1C3-23111-L1	.BOLT, CAP	1	1	1	1	
46	2HH-23158-L0	..GASKET	1	1	1	1	
47	276-23114-00	..GASKET	1	1	1	1	
48	1C3-2314F-M0	.PROTECTOR GUIDE COMP., 1	1	1	1	1	



5XCG100-F250

FIG. 25 FRONT FORK

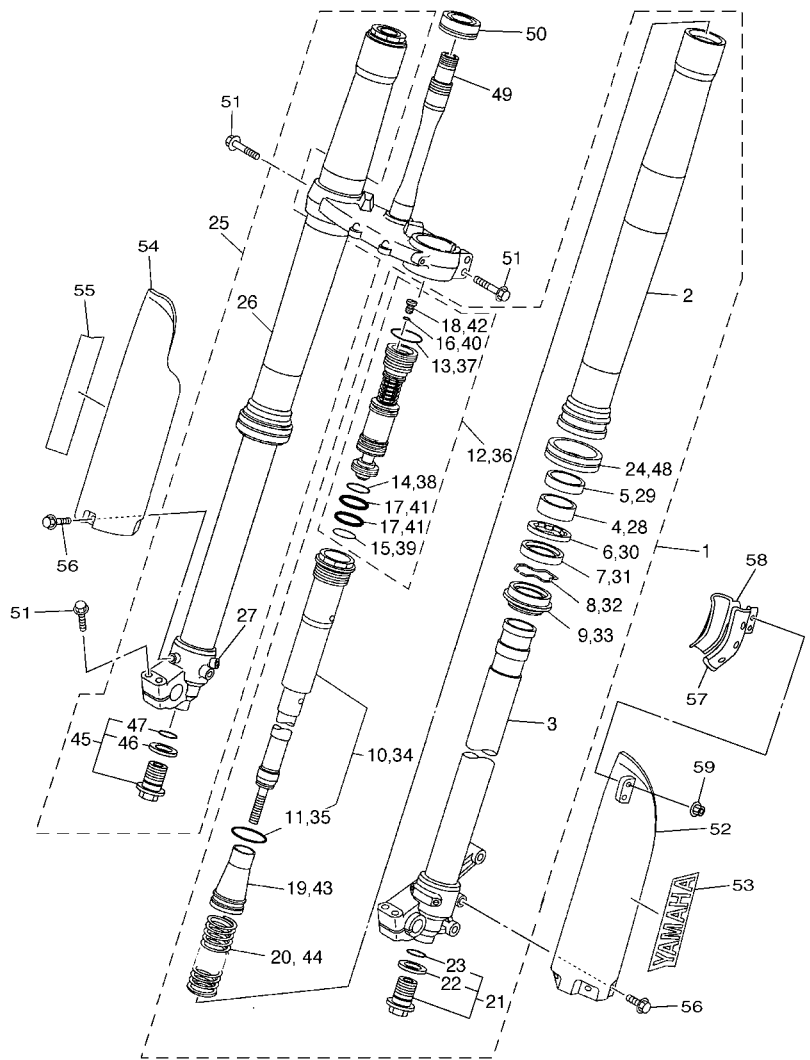

REF. NO.	PART NO.	DESCRIPTION	5XCJ	5XCH	5XCG	5XCK	REMARKS
49	5XC-23340-N0	UNDER BRACKET COMP.	1	1	1	1	
50	93332-00081	BEARING	1	1	1	1	
51	90105-08154	BOLT, FLANGE	8	8	8	8	
52	1C3-2315H-10	PROTECTOR 1	1	1	1	1	
53	4XL-2153A-10	EMBLEM, YAMAHA	1	1	1	1	
54	1C3-2315J-10	PROTECTOR 2	1	1	1	1	
55	4XL-2153A-10	EMBLEM, YAMAHA	1	1	1	1	
56	3SP-23356-L0	BOLT 2	6	6	6	6	
57	1C3-23466-50	CLAMP	1	1	1	1	
58	1C3-23467-50	CLAMP	1	1	1	1	
59	95702-06500	NUT, FLANGE	2	2	2	2	



5XCJ100-F250

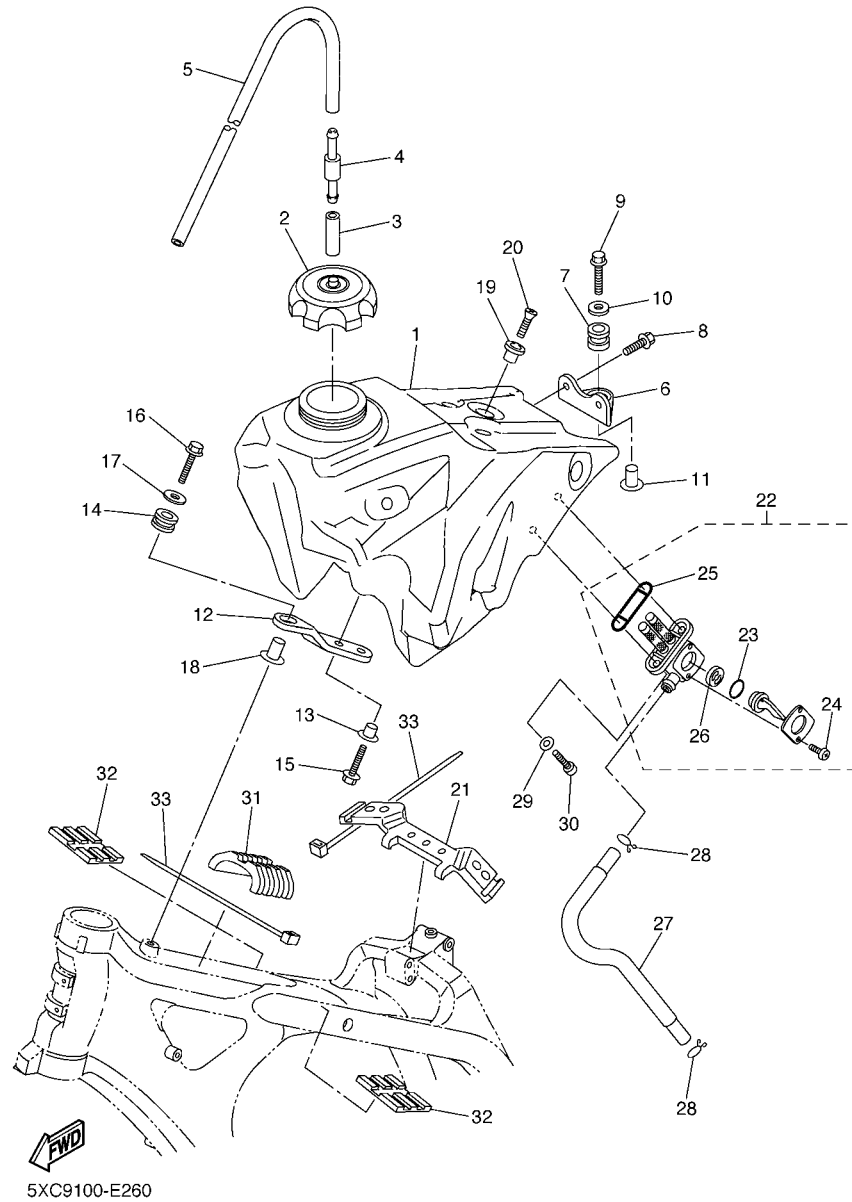

FIG. 26 FUEL TANK

REF. NO.	PART NO.	DESCRIPTION	5XCG	5XCH	5XCJ	5XCK	REMARKS
1	2S2-24110-70	FUEL TANK COMP.	1	1	1	1	
2	5NY-24610-00	CAP ASSY	1	1	1	1	
3	90445-09220	HOSE (L30)	1	1	1	1	
4	3XJ-24380-00	PIPE JOINT ASSY	1	1	1	1	
5	90445-09251	HOSE (L350)	1	1	1	1	
6	5XE-24144-00	HOLDER, DAMPER	1	1	1	1	
7	90480-18549	GROMMET	1	1	1	1	
8	90105-06107	BOLT, FLANGE	2	2	2	2	
9	90105-06111	BOLT, FLANGE	1	1	1	1	
10	90201-06570	WASHER, PLATE	1	1	1	1	
11	3JD-24186-00	WASHER, SPECIAL	1	1	1	1	
12	5UM-2419A-E0	HOLDER	1	1	1	1	
13	90387-06090	COLLAR	2	2	2	2	
14	5XC-24339-90	GROMMET	1	1	1	1	
15	90105-06107	BOLT, FLANGE	2	2	2	2	
16	90105-06111	BOLT, FLANGE	1	1	1	1	
17	90201-06570	WASHER, PLATE	1	1	1	1	
18	90387-06065	COLLAR	1	1	1	1	
19	4EW-2412F-00	BRACKET, SEAT	1	1	1	1	
20	98702-06025	SCREW, FLAT HEAD	1	1	1	1	
21	5XC-24181-90	DAMPER, LOCATING 1	1	1	1	1	
22	4JT-24500-10	FUEL COCK ASSY 1	1	1	1	1	
23	3AJ-24534-01	.SEAL, COCK	1	1	1	1	
24	98502-03008	.SCREW, PAN HEAD	2	2	2	2	
25	4X8-24512-00	.O-RING	1	1	1	1	
26	3AC-24523-00	.VALVE PACKING	1	1	1	1	
27	5XC-24311-G0	PIPE, FUEL 1	1	1	1	1	

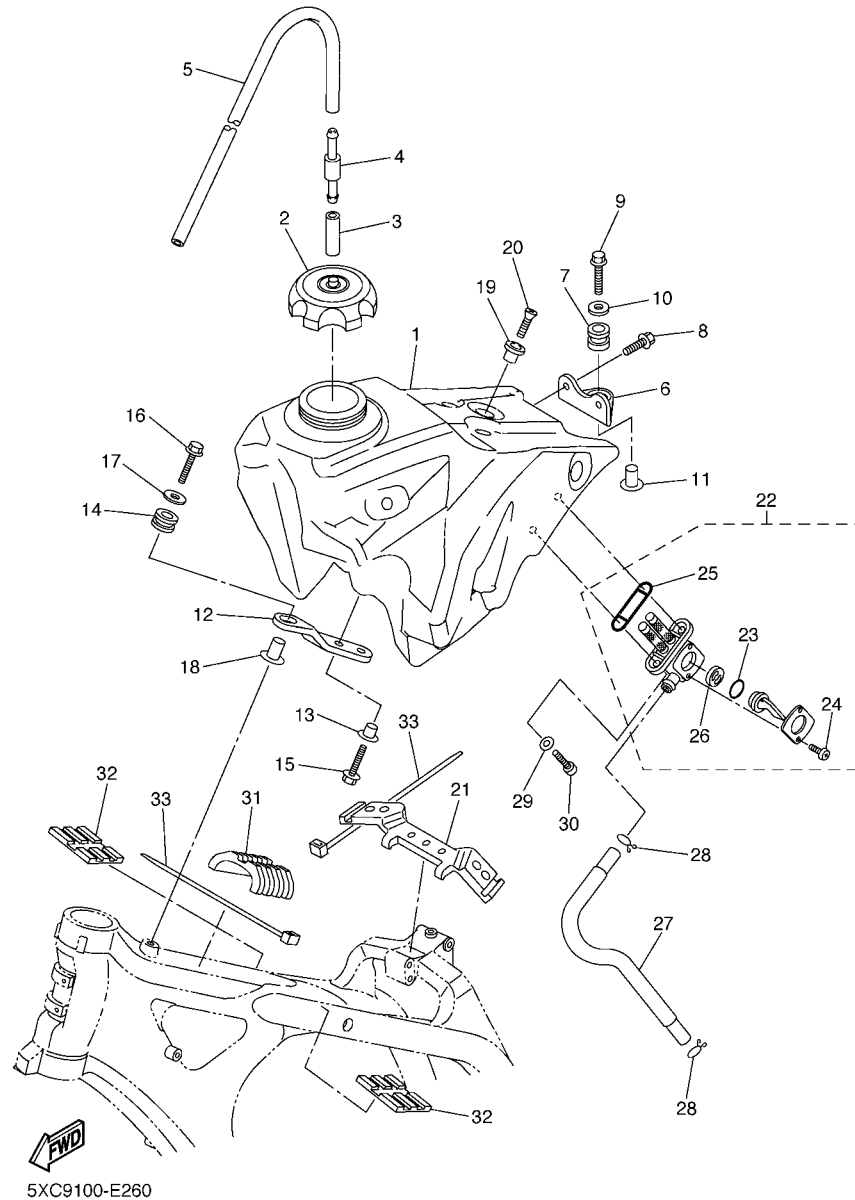
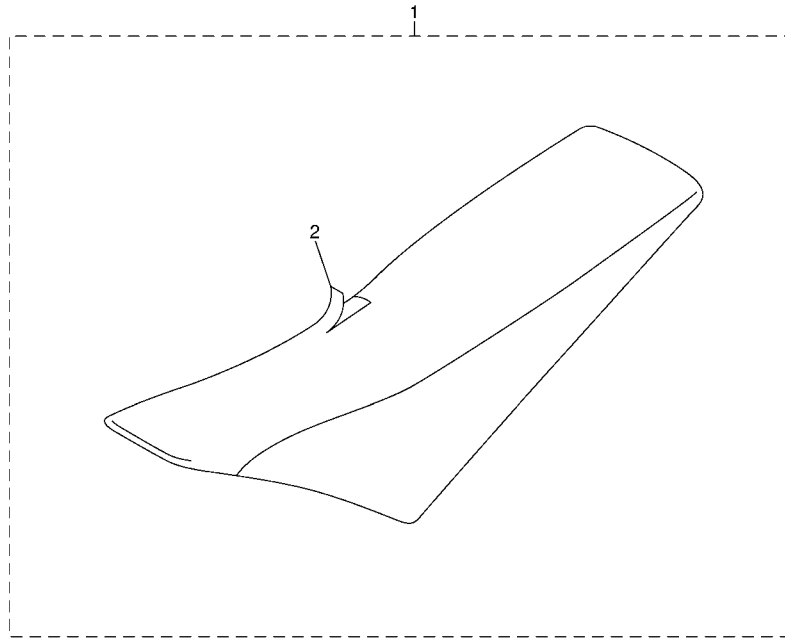

FIG. 26 FUEL TANK

REF. NO.	PART NO.	DESCRIPTION	5XCG	5XCH	5XCJ	5XCK	REMARKS
28	90467-100A1	CLIP	2	2	2	2	
29	90202-05193	WASHER, PLATE	2	2	2	2	
30	90149-06108	SCREW	2	2	2	2	
31	5XC-24182-90	DAMPER, LOCATING 2	1	1	1	1	
32	5XC-24183-90	DAMPER, LOCATING 3	2	2	2	2	
33	90465-13275	CLAMP	3	3	3	3	

FIG. 27 SEAT



REF. NO.	PART NO.	DESCRIPTION	5XCG	5XCH	5XCJ	5XCK	REMARKS
1	2S2-24710-70	SINGLE SEAT ASSY	1		1	1	UR FOR DPBSE
	2S2-24710-80	SINGLE SEAT ASSY	1		1	1	UR FOR PWS1
2	5XC-2470F-90	.SEAT COVER COMP.	1		1	1	UR FOR DPBSE
	2S2-2470F-80	.SEAT COVER COMP.	1		1	1	UR FOR PWS1



5XC9100-E270

FIG. 28 FRONT WHEEL

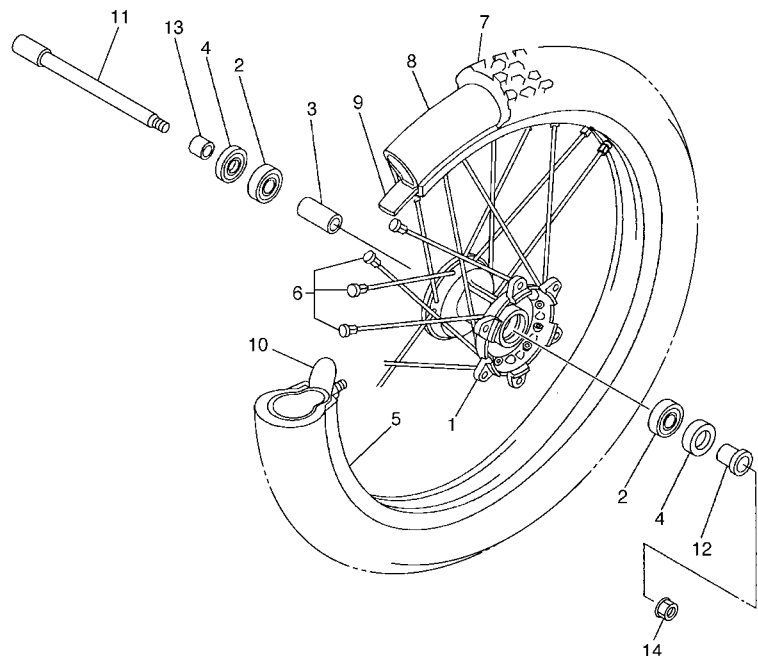

REF. NO.	PART NO.	DESCRIPTION	5XCG	5XCH	5XCJ	5XCK	REMARKS
1	5NY-25111-00	HUB, FRONT	1	1	1	1	
2	93306-90409	BEARING	2	2	2	2	
3	5NY-25117-00	SPACER, BEARING	1	1	1	1	
4	93102-26468	OIL SEAL	2	2	2	2	
5	94416-21034	RIM (1.60-21)	1	1	1	1	
6	5NY-25104-00	SPOKE SET, FRONT	1	1	1	1	
7	L.M.	TIRE (80/100-21 51M D739FA)				1	
8	L.M.	TUBE (80/100-21 M/C TR4)				1	
9	94309-21161	BAND, RIM (1.60-21)	1	1		1	DUNLOP
10	5SF-25394-00	SPACER, BEAD	1	1	1	1	
11	5XC-25181-G0	AXLE, WHEEL	1	1	1	1	
12	5XC-25183-G0	COLLAR, WHEEL	1	1	1	1	
13	5XC-25186-G0	COLLAR, WHEEL	1	1	1	1	
14	90179-16011	NUT	1	1	1	1	



5XD5100-D280

FIG. 29 FRONT BRAKE CALIPER

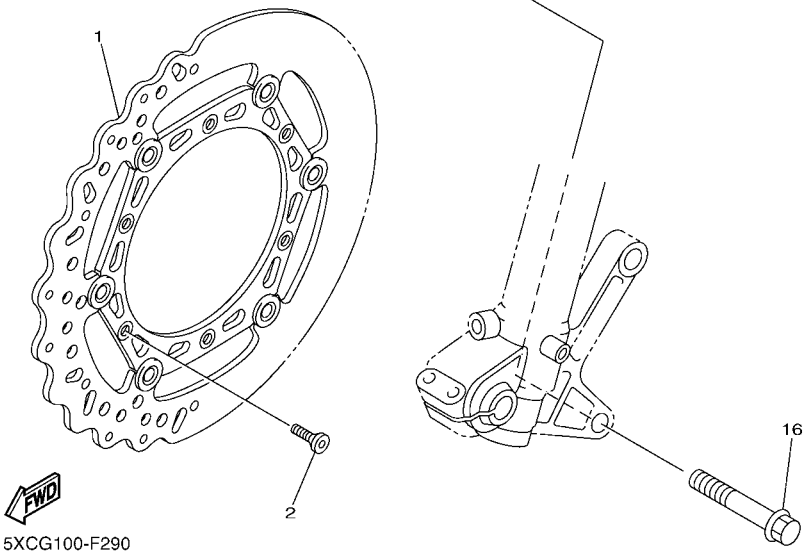
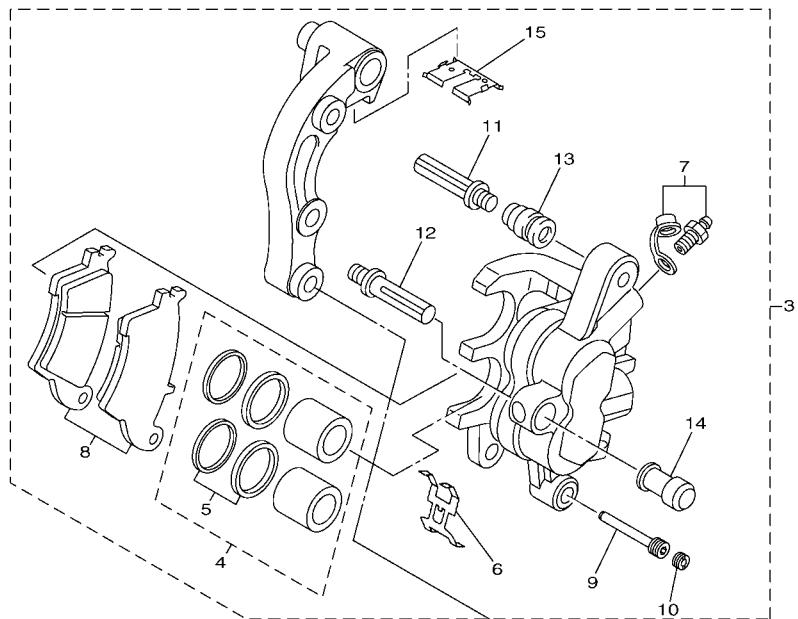

REF. NO.	PART NO.	DESCRIPTION	5XCG	5XCH	5XCJ	5XCK	REMARKS
1	5XC-2581T-G0	DISK BRAKE ASSY	1	1	1	1	
2	90149-06327	SCREW	6	6	6	6	
3	5XC-2580T-G0	CALIPER ASSY (LEFT)	1	1	1	1	
4	5XC-W0057-00	.PISTON ASSY, CALIPER	1	1	1	1	
5	5KM-W0047-10	..CALIPER SEAL KIT	1	1	1	1	
6	5DH-25919-00	.SUPPORT, PAD	1	1	1	1	
7	1UY-W0048-50	.BLEED SCREW KIT	1	1	1	1	
8	5XC-W0045-00	.BRAKE PAD KIT	1	1	1	1	
9	5DH-25933-00	.PIN, PAD	1	1	1	1	
10	5DH-25916-00	.PLUG	1	1	1	1	
11	3SP-25926-51	.BOLT	1	1	1	1	
12	3SP-25914-51	.PIN, SLIDE	1	1	1	1	
13	3JD-25917-00	.BOOT, CALIPER	1	1	1	1	
14	1UY-25937-51	.BOOT 2	1	1	1	1	
15	5XC-25849-G0	.RETAINER, CALIPER	1	1	1	1	
16	90105-08137	BOLT, FLANGE	2	2	2	2	

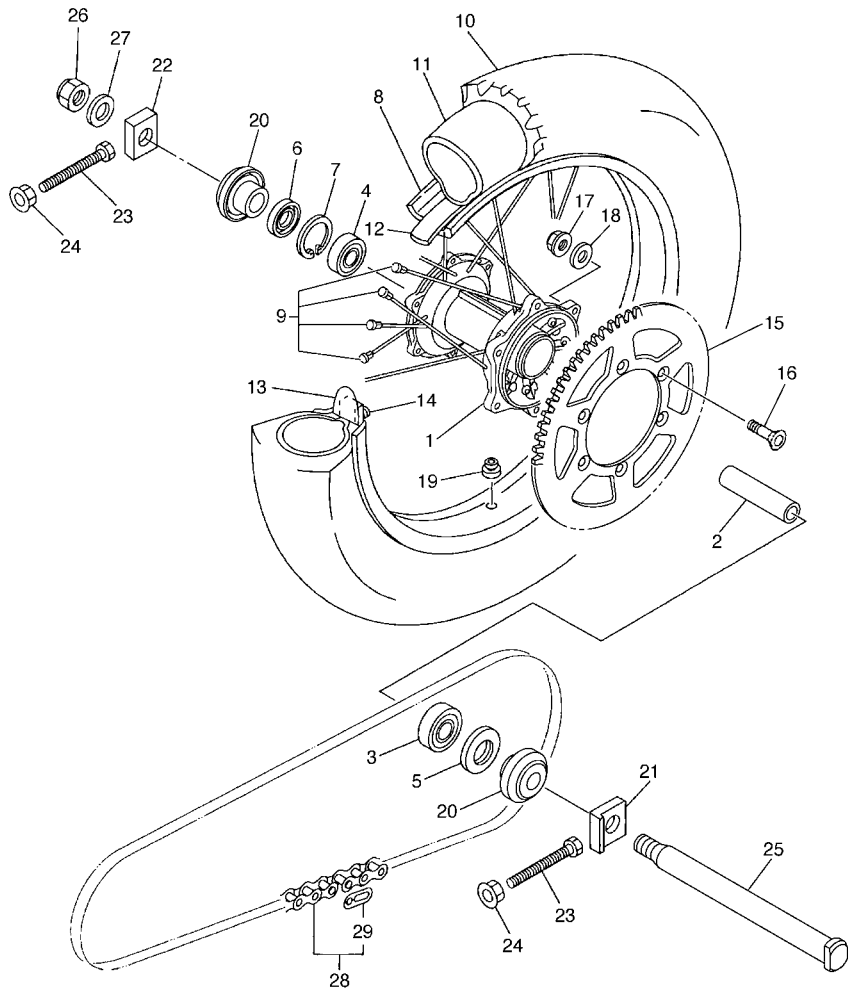

5XC9100-E300

FIG. 30 REAR WHEEL

REF. NO.	PART NO.	DESCRIPTION	5XCG	5XCH	5XCJ	5XCK	REMARKS
1	5ET-25311-00	HUB, REAR	1	1	1	1	
2	5ET-25317-00	SPACER, BEARING	1	1	1	1	
3	93306-27212	BEARING	1	1	1	1	
4	93306-07202	BEARING	1	1	1	1	
5	93106-30001	OIL SEAL	1	1	1	1	
6	93106-30045	OIL SEAL	1	1	1	1	
7	99009-45500	CIRCLIP	1	1	1	1	
8	94418-19008	RIM (1.85-19)	1	1	1	1	
9	5HD-25304-00	SPOKE SET, REAR	1	1	1	1	
10	L.M.	TIRE (100/90-19 57M D756)				1	
11	L.M.	TUBE (100/90-19 M/C TR4 BTL)				1	
12	94321-19135	BAND, RIM (1.85-19)	1	1		1	DUNLOP
13	4XM-25394-00	SPACER, BEAD	1	1	1	1	
14	4XM-25364-00	DAMPER	1	1	1	1	
15	1C3-25449-00	SPROCKET, DRIVEN (49T)	1	1	1	1	STD
	1C3-25447-00	SPROCKET, DRIVEN (47T)	1	1	1	1	AP
	1C3-25448-00	SPROCKET, DRIVEN (48T)	1	1	1	1	AP
	1C3-25450-00	SPROCKET, DRIVEN (50T)	1	1	1	1	AP
	1C3-25451-00	SPROCKET, DRIVEN (51T)	1	1	1	1	AP
	1C3-25452-00	SPROCKET, DRIVEN (52T)	1	1	1	1	AP

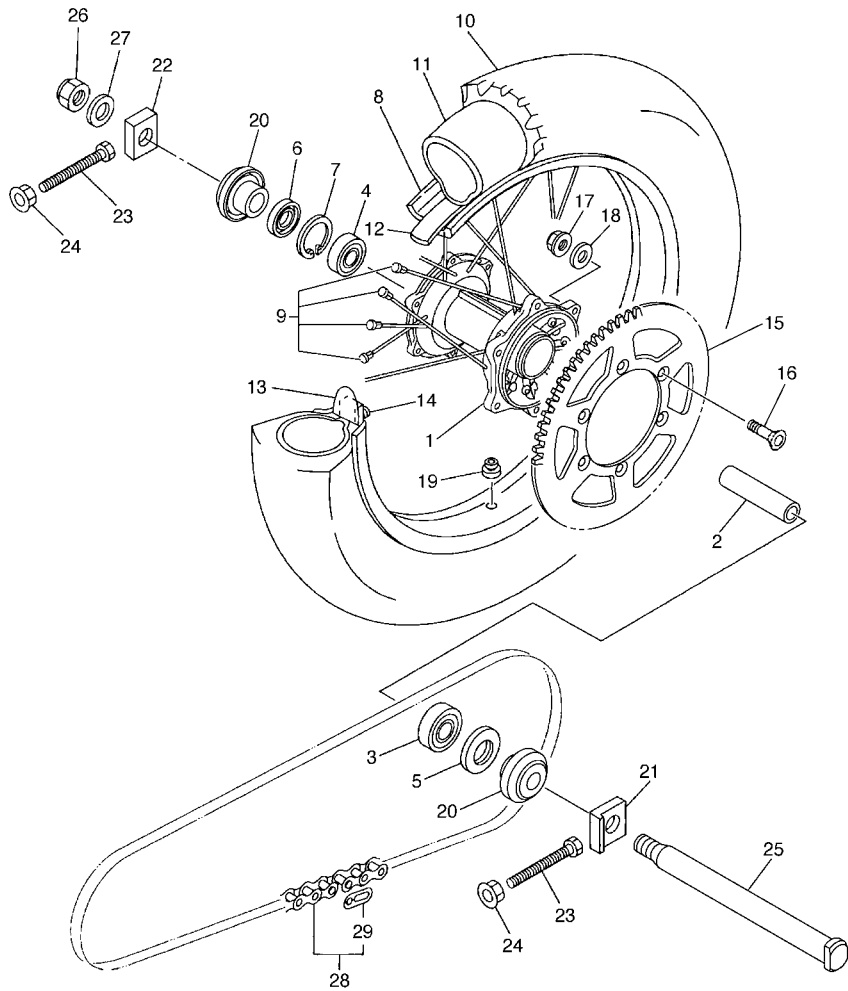

FIG. 30 REAR WHEEL

REF. NO.	PART NO.	DESCRIPTION	5XCG	5XCH	5XCJ	5XCK	REMARKS
16	90109-08078	BOLT	6	6	6	6	
17	90185-08008	NUT, SELF-LOCKING	6	6	6	6	
18	90201-08048	WASHER, PLATE	6	6	6	6	
19	90480-08608	GROMMET	1	1	1	1	
20	5TJ-2530S-80	COLLAR ASSY	2	2	2	2	
21	1C3-25388-50	PULLER, CHAIN 1	1	1	1	1	
22	1C3-25389-00	PULLER, CHAIN 2	1	1	1	1	
23	90101-08006	BOLT	2	2	2	2	
24	90179-08674	NUT	2	2	2	2	
25	1C3-25381-90	AXLE, WHEEL	1	1	1	1	
26	90185-20002	NUT, SELF-LOCKING	1	1	1	1	
27	90201-20020	WASHER, PLATE	1	1	1	1	
28	9Y581-92111	CHAIN (DID 520D 112L)	1	1	1	1	
29	94681-68001	.JOINT,CHAIN (DID 520DM-RJ)	1	1	1	1	



5XC9100-E300

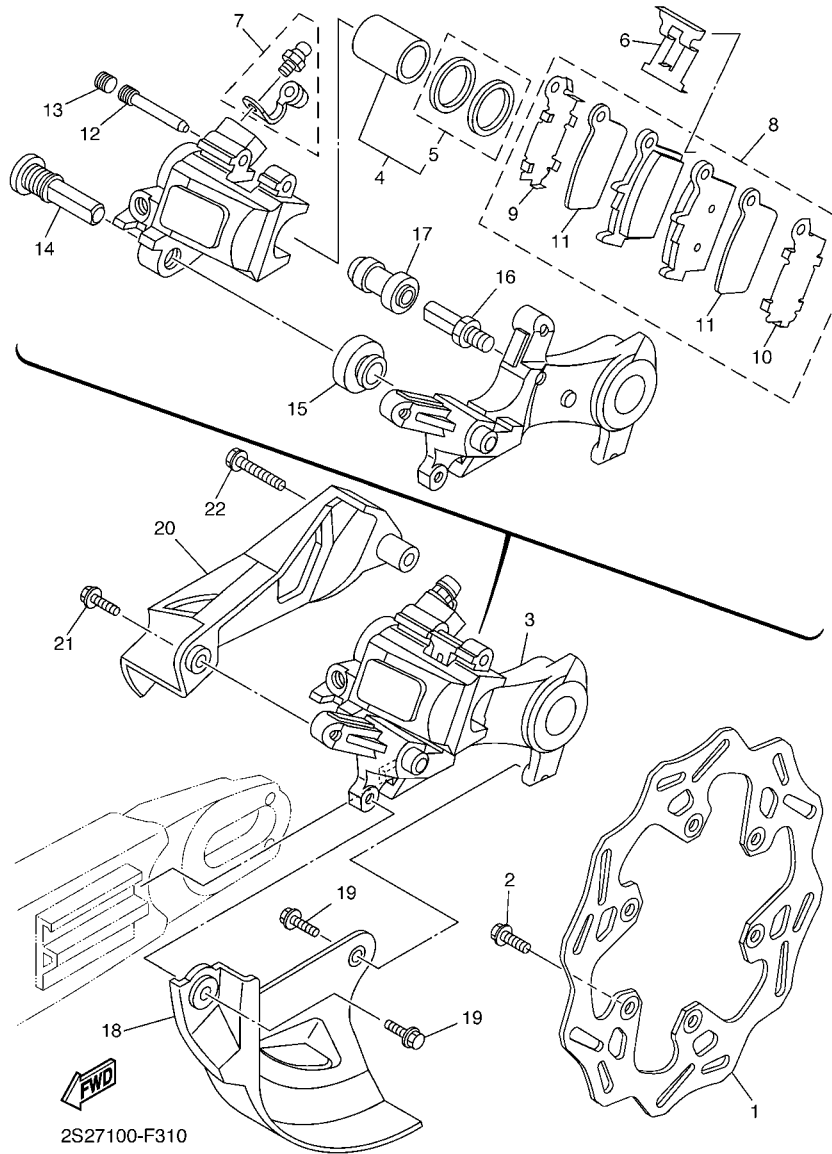
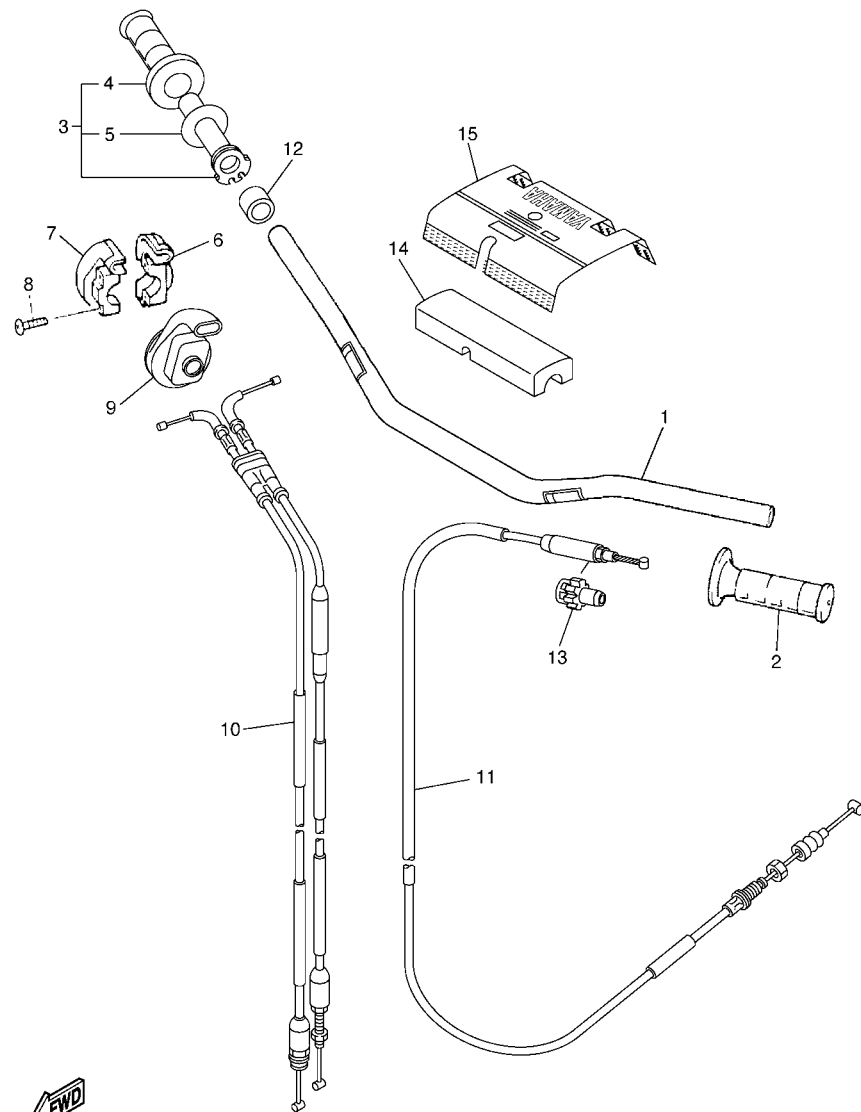

FIG. 31 REAR BRAKE CALIPER

REF. NO.	PART NO.	DESCRIPTION	5XCG	5XCH	5XCJ	5XCK	REMARKS
1	2S2-2582W-70	DISK, REAR BRAKE 2	1	1	1	1	
2	90105-06108	BOLT, FLANGE	6	6	6	6	
3	1C3-2580W-50	CALIPER ASSY, REAR 2	1	1	1	1	
4	5UN-W0057-50	.PISTON ASSY, CALIPER	1	1	1	1	
5	5UN-W0047-50	..CALIPER SEAL KIT	1	1	1	1	
6	5DH-25919-50	..SUPPORT, PAD	1	1	1	1	
7	1UY-W0048-50	.BLEED SCREW KIT	1	1	1	1	
8	1C3-W0046-50	.BRAKE PAD KIT 2	1	1	1	1	
9	5UN-25828-60	..SHIM, CALIPER	1	1	1	1	
10	5UN-25827-60	..SHIM, CALIPER	1	1	1	1	
11	5UN-22898-60	..INSULATOR, HEAT	2	2	2	2	
12	8CR-25924-00	.PIN, PAD	1	1	1	1	
13	5DH-25916-00	.PLUG	1	1	1	1	
14	5DH-25914-50	.PIN, SLIDE	1	1	1	1	
15	3JD-25917-00	.BOOT, CALIPER	1	1	1	1	
16	5UN-25914-00	.PIN, SLIDE	1	1	1	1	
17	1UY-25937-51	.BOOT 2	1	1	1	1	
18	1C3-25718-50	PROTECTOR, DISK BRAKE	1	1	1	1	
19	90105-06110	BOLT, FLANGE	2	2	2	2	
20	1C3-27491-50	PROTECTOR	1	1	1	1	
21	90105-06107	BOLT, FLANGE	1	1	1	1	
22	90105-06111	BOLT, FLANGE	1	1	1	1	



5XC9100-E320

FIG. 32 STEERING HANDLE & CABLE

REF. NO.	PART NO.	DESCRIPTION	5XCG	5XCH	5XCJ	5XCK	REMARKS
1	1C3-26111-90	HANDLEBAR	1	1	1	1	
2	4GY-26241-00	GRIP	1	1	1	1	
3	5TJ-26240-C0	GRIP ASSY	1	1	1	1	
4	4GY-26242-00	.GRIP (RIGHT)	1	1	1	1	
5	3Y1-26249-00	.RING, LEAF	1	1	1	1	
6	5BE-26281-00	CAP, GRIP UPPER	1	1	1	1	
7	5BE-26282-00	CAP, GRIP LOWER	1	1	1	1	
8	98502-05020	SCREW, PAN HEAD	2	2	2	2	
9	5SF-26287-10	COVER, CAP GRIP	1	1	1	1	
10	5XC-26302-G0	THROTTLE CABLE ASSY	1	1	1	1	
11	5XC-26335-G0	CABLE, CLUTCH	1	1	1	1	
12	90387-225N2	COLLAR	1	1	1	1	
13	1C3-26342-50	BOOT, CABLE	1	1	1	1	
14	5XC-26124-90	PROTECTOR, HANDLEBAR	1	1	1	1	
15	5XC-26143-90	COVER, HANDLEBAR UPPER 1	1	1	1	1	UR FOR DPBSE
	2S2-26143-70	COVER, HANDLEBAR UPPER 1	1	1	1	1	UR FOR PWS1

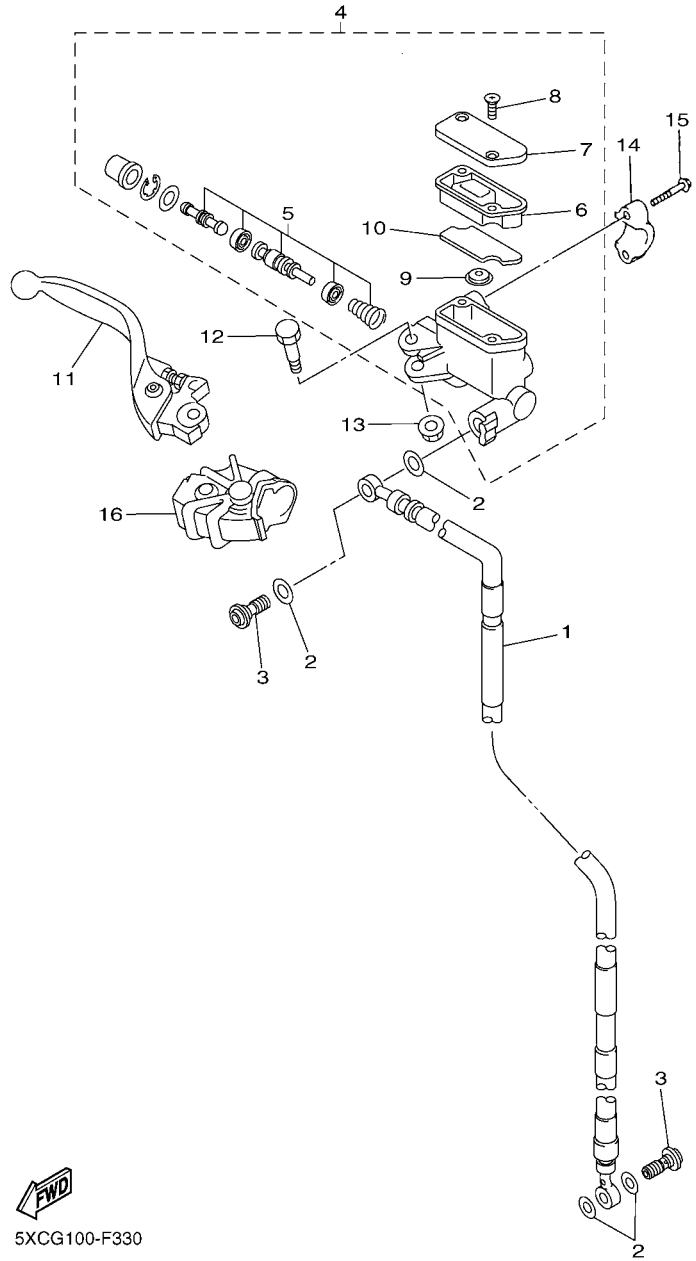

FWD
5XCG100-F330

FIG. 33 FRONT MASTER CYLINDER

REF. NO.	PART NO.	DESCRIPTION	5XCG	5XCH	5XCJ	5XCK	REMARKS
1	1C3-25872-90	HOSE, BRAKE 1	1	1	1	1	
2	90430-10005	GASKET	4	4	4	4	
3	90401-10172	BOLT, UNION	2	2	2	2	
4	5XC-W2587-00	MASTER CYLINDER SUB ASSY	1	1	1	1	
5	5XC-W0041-00	.CYLINDER KIT, MASTER	1	1	1	1	
6	5XC-25854-G0	.DIAPHRAGM, RESERVOIR	1	1	1	1	
7	5XC-25852-G0	.CAP, RESERVOIR	1	1	1	1	
8	98706-04012	.SCREW, FLAT HEAD	2	2	2	2	
9	5CG-25715-00	.SEPARATOR ASSY	1	1	1	1	
10	5XC-25853-G0	.FLOAT, RESERVOIR	1	1	1	1	
11	5XC-83922-G0	LEVER 2	1	1	1	1	
12	5MV-2589F-00	BOLT, LEVER	1	1	1	1	
13	95701-06500	NUT, FLANGE	1	1	1	1	
14	5MV-25867-00	BRACKET, MASTER CYLINDER	1	1	1	1	
15	5MV-25833-00	BOLT, FITTING	2	2	2	2	
16	5XC-26372-G0	COVER, HANDLE LEVER 1	1	1	1	1	

FIG. 34 STAND & FOOTREST

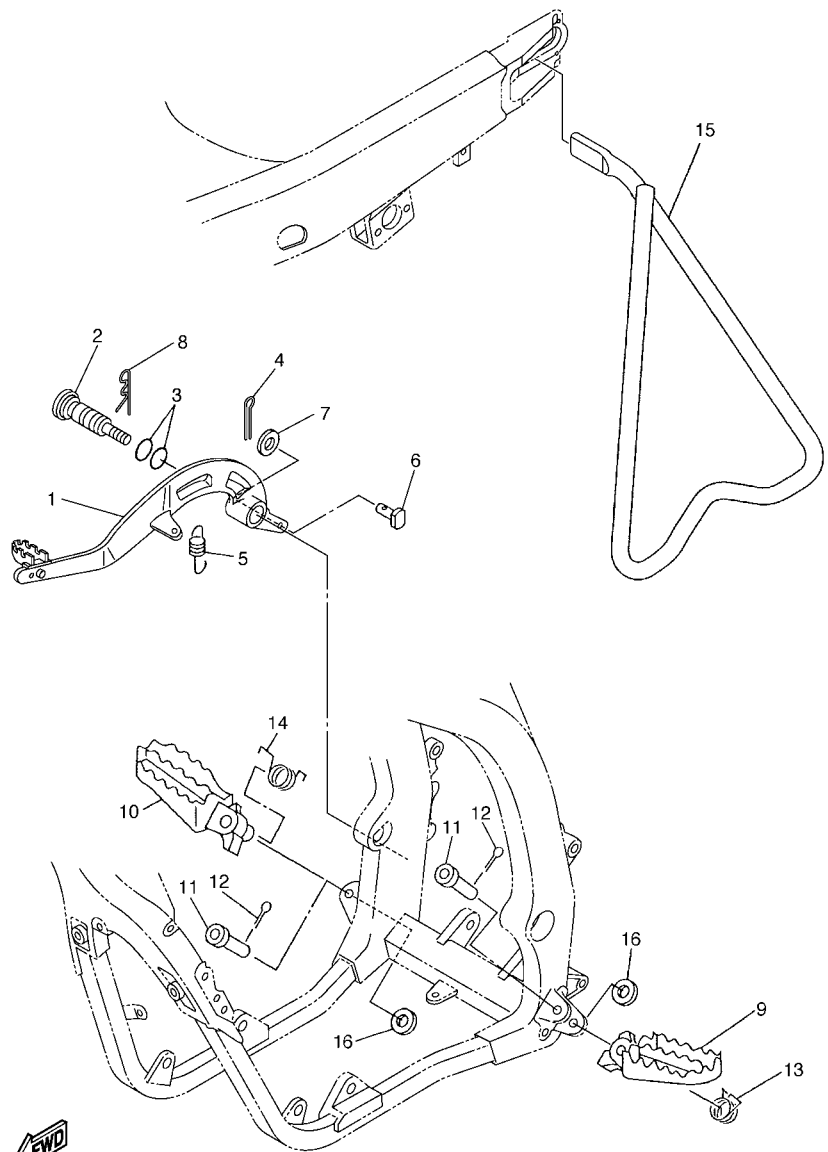

5XC9100-E340

REF. NO.	PART NO.	DESCRIPTION	5XCG	5XCH	5XCJ	5XCK	REMARKS
1	5UM-27200-00	PEDAL, BRAKE	1	1	1	1	
2	5XC-27217-90	BOLT	1	1	1	1	
3	93210-11073	O-RING	2	2	2	2	
4	91402-20012	PIN, COTTER	1	1	1	1	
5	90506-16007	SPRING, TENSION	1	1	1	1	
6	90240-08120	PIN, CLEVIS	1	1	1	1	
7	90201-08044	WASHER, PLATE	1	1	1	1	
8	90468-16001	CLIP	1	1	1	1	
9	5XE-27411-01	FOOTREST 1	1	1	1	1	
10	5XE-27421-01	FOOTREST 2	1	1	1	1	
11	90240-10004	PIN, CLEVIS	2	2	2	2	
12	91402-25015	PIN, COTTER	2	2	2	2	
13	90508-28015	SPRING, TORSION	1	1	1	1	
14	90508-28018	SPRING, TORSION	1	1	1	1	
15	1C3-27311-00	STAND, SIDE	1	1	1	1	
16	90201-10032	WASHER, PLATE	2	2	2	2	

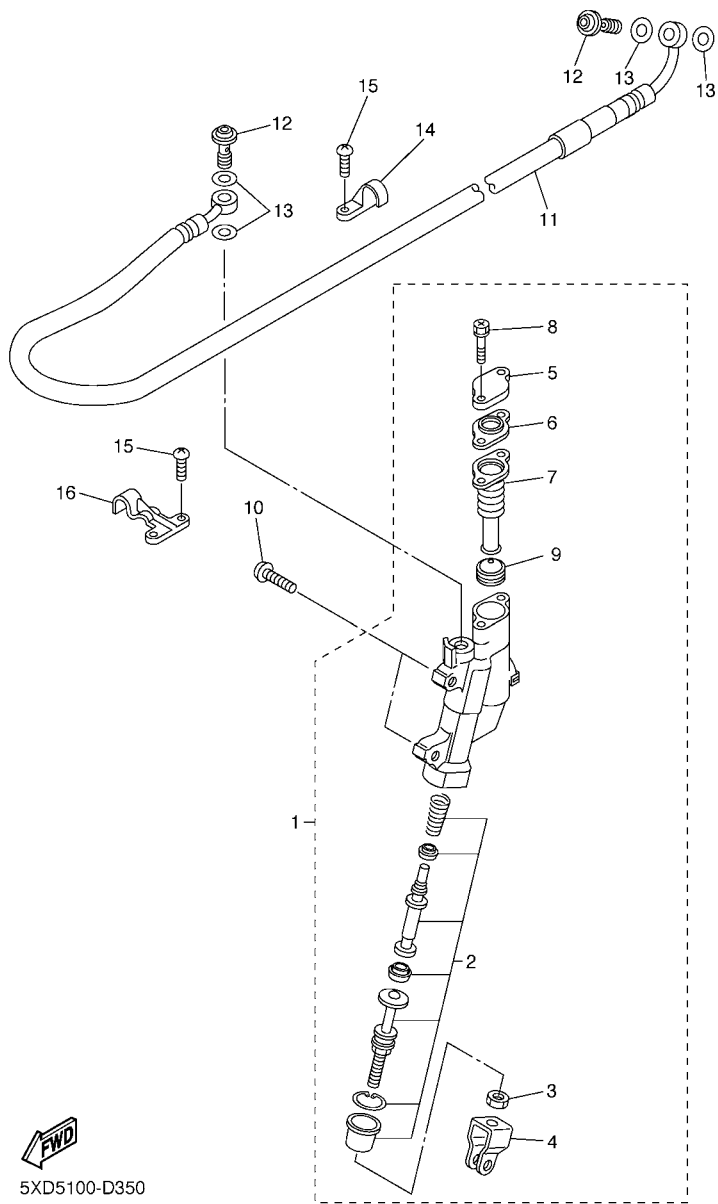

5XD5100-D350

FIG. 35 REAR MASTER CYLINDER

REF. NO.	PART NO.	DESCRIPTION	5XCG	5XCH	5XCJ	5XCK	REMARKS
1	1C3-2583V-00	RR. MASTER CYLINDER ASSY.	1	1	1	1	
2	5UN-W0042-50	.CYLINDER KIT, MASTER	1	1	1	1	
3	5UN-27218-00	.NUT	1	1	1	1	
4	5UN-27222-00	.JOINT	1	1	1	1	
5	5UN-25852-50	.CAP, RESERVOIR	1	1	1	1	
6	5UN-2585B-00	.PLATE, DIAPHRAGM	1	1	1	1	
7	5UN-25854-00	.DIAPHRAGM, RESERVOIR	1	1	1	1	
8	5UN-27217-00	.BOLT	2	2	2	2	
9	5CG-25715-00	.SEPARATOR ASSY	1	1	1	1	
10	90111-06059	BOLT,HEX. SOCKET BUTTON	2	2	2	2	
11	1C3-25873-00	HOSE, BRAKE 2	1	1	1	1	
12	90401-10172	BOLT, UNION	2	2	2	2	
13	90430-10005	GASKET	4	4	4	4	
14	1C3-25886-50	HOLDER, BRAKE HOSE	1	1	1	1	
15	98502-05010	SCREW, PAN HEAD	4	4	4	4	
16	1C3-25876-50	HOLDER, BRAKE HOSE 2	1	1	1	1	

FIG. 36 GENERATOR

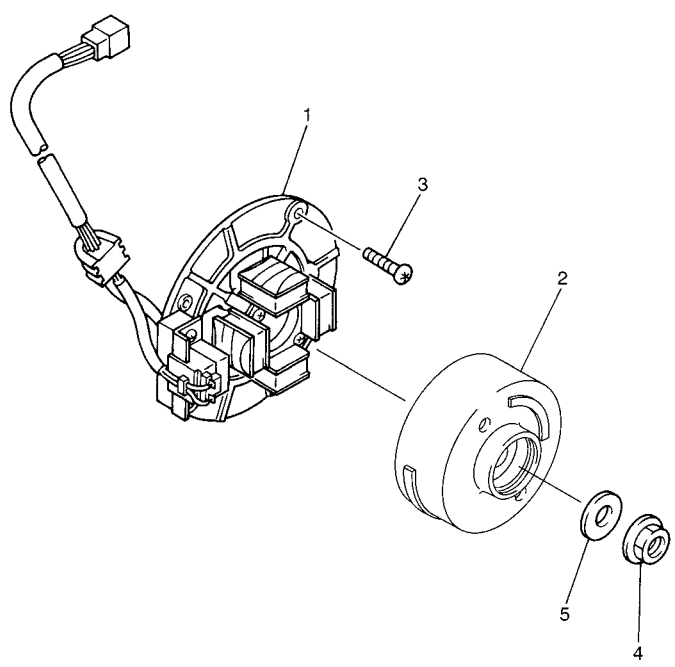

REF. NO.	PART NO.	DESCRIPTION	5XCJ	5XCH	5XCJ	5XCK	REMARKS
1	5XC-85560-00	BASE ASSY	1	1	1	1	
2	5TA-85550-00	ROTOR ASSY	1	1	1	1	
3	90149-06121	SCREW	3	3	3	3	
4	90179-12657	NUT	1	1	1	1	
5	90201-127E1	WASHER, PLATE	1	1	1	1	



5TA1100-B360

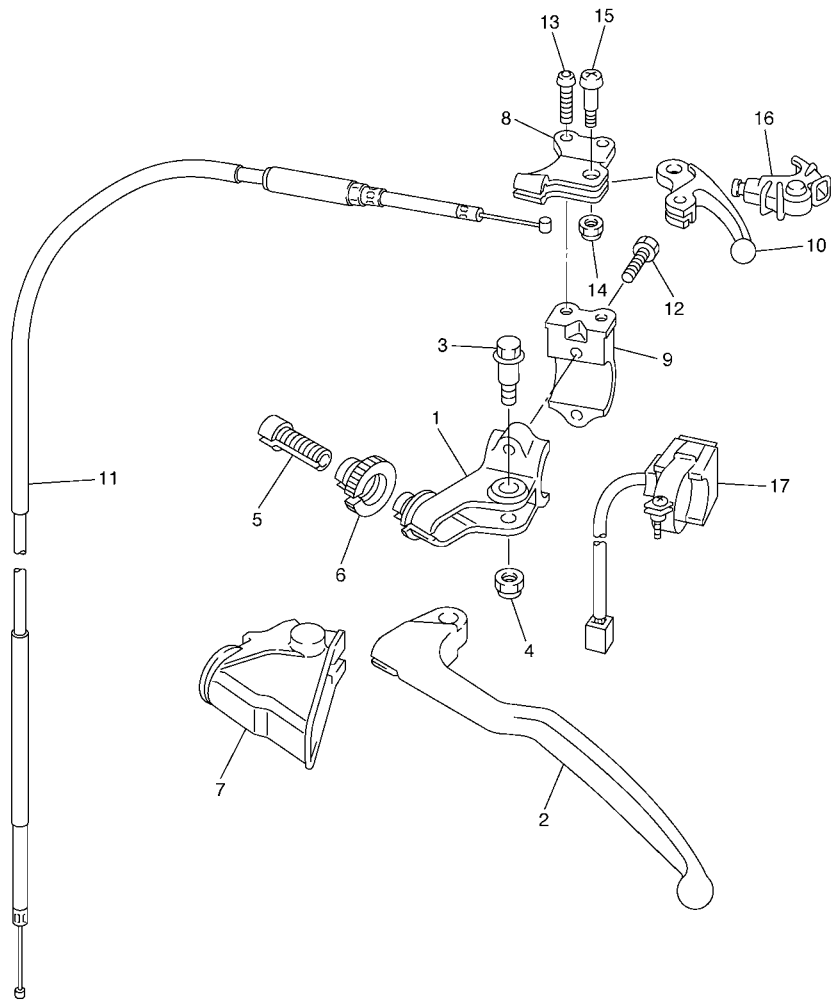

5XC9100-E370

FIG. 37 HANDLE SWITCH & LEVER

REF. NO.	PART NO.	DESCRIPTION	5XCG	5XCH	5XCJ	5XCK	REMARKS
1	5XE-82911-00	HOLDER, LEVER 1	1	1	1	1	
2	5MV-83912-00	LEVER 1	1	1	1	1	
3	90109-06034	BOLT	1	1	1	1	
4	5LP-84126-10	NUT, LENS FITTING	1	1	1	1	
5	5HD-26337-00	BOLT, ADJUSTING	1	1	1	1	
6	5HD-83951-00	BOLT, CABLE ADJUSTING	1	1	1	1	
7	5HD-26372-00	COVER, HANDLE LEVER 1	1	1	1	1	
8	5XD-82946-00	HOLDER, STARTER LEVER	1	1	1	1	
9	5XD-82913-00	HOLDER, LEVER LOWER 1	1	1	1	1	
10	5TA-83941-00	LEVER, STARTER	1	1	1	1	
11	5XC-26334-G0	CABLE, STARTER 2	1	1	1	1	
12	97002-05016	BOLT	2	2	2	2	
13	92012-05012	BOLT, BUTTON HEAD	2	2	2	2	
14	95602-05100	NUT, U	1	1	1	1	
15	90149-05162	SCREW	1	1	1	1	
16	5TA-26339-00	BOOT	1	1	1	1	
17	1C3-83976-00	SWITCH, HANDLE 1	1	1	1	1	

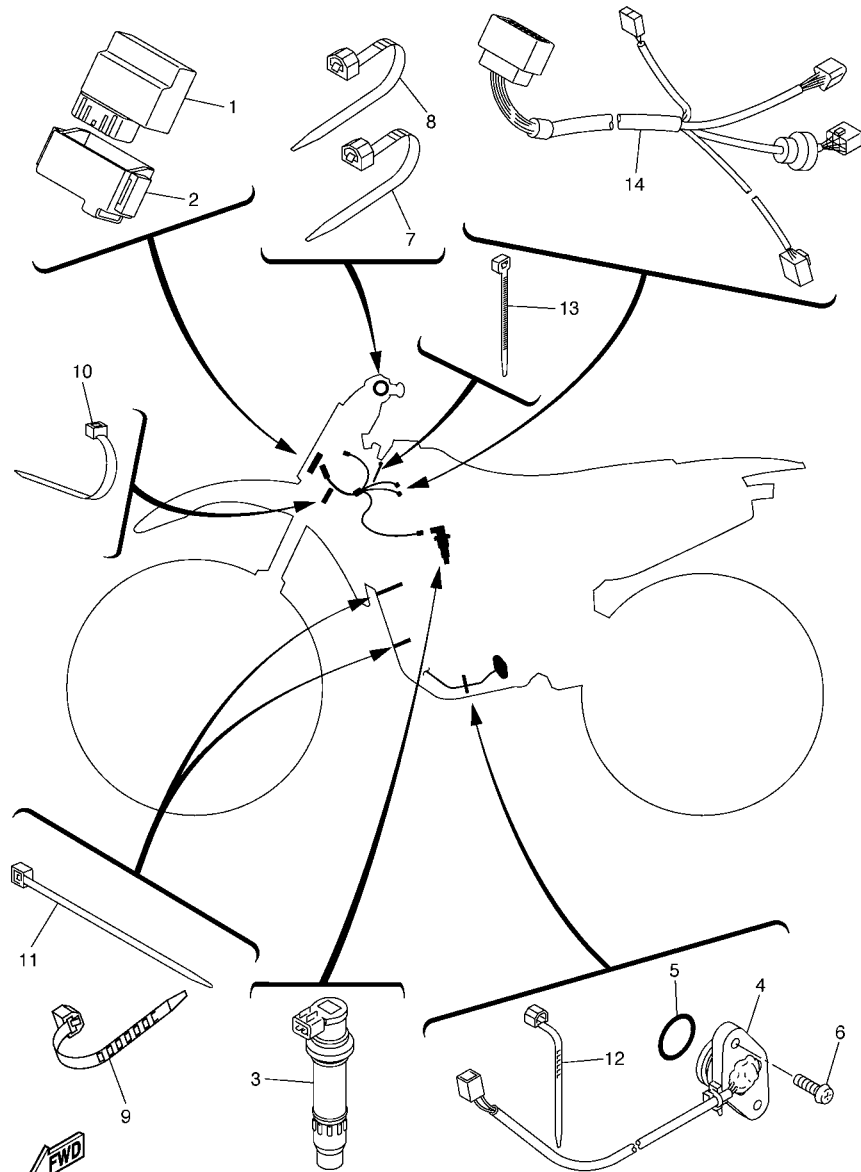

5XC9100-E380

FIG. 38 ELECTRICAL 1

REF. NO.	PART NO.	DESCRIPTION	5XCG	5XCH	5XCJ	5XCK	REMARKS
1	5XC-85540-G0	C.D.I. UNIT ASSY	1	1	1	1	
2	1C3-85546-00	BAND	1	1	1	1	
3	5UL-82310-10	IGNITION COIL ASSY	1	1	1	1	
4	5XC-82540-00	NEUTRAL SWITCH ASSY	1	1	1	1	
5	93210-21276	O-RING	1	1	1	1	
6	90154-05022	SCREW, BINDING	2	2	2	2	
7	90464-13077	CLAMP	1	1	1	1	
8	90464-13073	CLAMP	1	1	1	1	
9	90464-15195	CLAMP	1	1	1	1	
10	5Y9-12491-00	CLAMP 1	1	1	1	1	
11	90465-13275	CLAMP	4	4	4	4	
12	5Y9-12491-00	CLAMP 1	2	2	2	2	
13	90465-13275	CLAMP	1	1	1	1	
14	5XC-82509-00	WIRE, SUB LEAD	1	1	1	1	

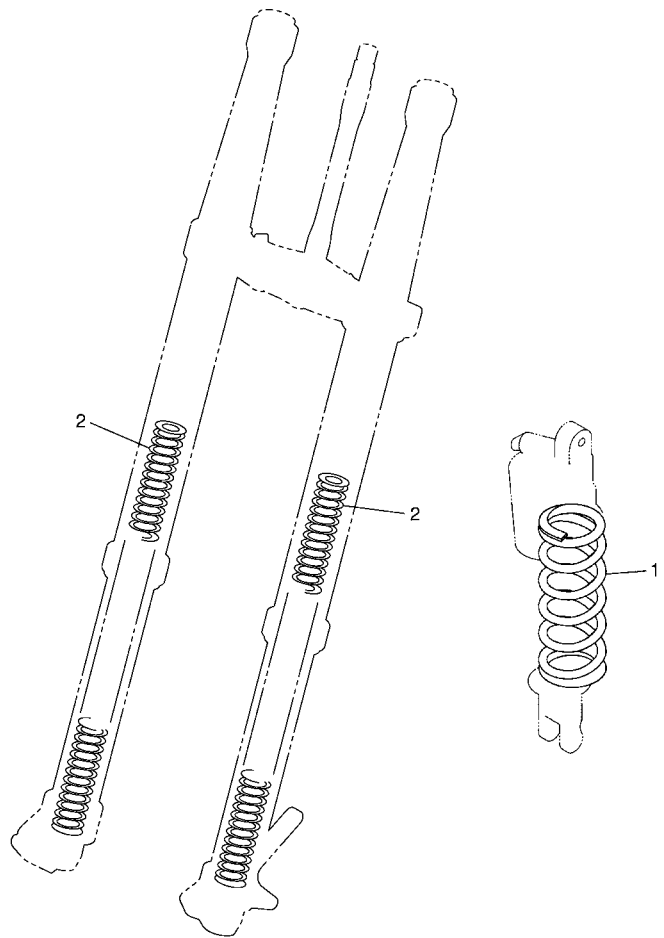

FIG. 39 ALTERNATE FOR CHASSIS

REF. NO.	PART NO.	DESCRIPTION	5XCG	5XCH	5XCJ	5XCK	REMARKS
1	5UN-22212-00	SPRING (K=42N/MM)	1	1	1	1	AP
	1C3-22212-00	SPRING (K=44N/MM)	1	1	1	1	AP
	1C3-22212-10	SPRING (K=46N/MM)	1	1	1	1	AP
	1C3-22212-30	SPRING (K=50N/MM)	1	1	1	1	AP
	1C3-22212-40	SPRING (K=52N/MM)	1	1	1	1	AP
	1C3-22212-50	SPRING (K=54N/MM)	1	1	1	1	AP
	1C3-22212-60	SPRING (K=55.8N/MM)	1	1	1	1	AP
	5UN-22212-A0	SPRING (K=APPROX.44N/MM)	1	1	1	1	AP
	5UN-22212-B0	SPRING (K=APPROX.46N/MM)	1	1	1	1	AP
	5UN-22212-C0	SPRING (K=APPROX.48N/MM)	1	1	1	1	AP
	5UN-22212-D0	SPRING (K=APPROX.50N/MM)	1	1	1	1	AP
	5UN-22212-E0	SPRING (K=APPROX.52N/MM)	1	1	1	1	AP
	5UN-22212-F0	SPRING (K=APPROX.54N/MM)	1	1	1	1	AP
	5UN-22212-G0	SPRING (K=APPROX.56N/MM)	1	1	1	1	AP
2	1C3-23141-A1	SPRING, FRONT FORK(K=3.9N/MM)	2	2	2	2	AP
	1C3-23141-B1	SPRING, FRONT FORK(K=4.0N/MM)	2	2	2	2	AP
	1C3-23141-C1	SPRING, FRONT FORK(K=4.1N/MM)	2	2	2	2	AP
	1C3-23141-E1	SPRING, FRONT FORK(K=4.3N/MM)	2	2	2	2	AP
	1C3-23141-F1	SPRING, FRONT FORK(K=4.4N/MM)	2	2	2	2	AP
	1C3-23141-G1	SPRING, FRONT FORK(K=4.5N/MM)	2	2	2	2	AP
	1C3-23141-H1	SPRING, FRONT FORK(K=4.6N/MM)	2	2	2	2	AP
	1C3-23141-J1	SPRING, FRONT FORK(K=4.7N/MM)	2	2	2	2	AP



5XC9100-E390

NUMERICAL INDEX

PART NO.	GRID NO.	PART NO.	GRID NO.	PART NO.	GRID NO.	PART NO.	GRID NO.	PART NO.	GRID NO.	PART NO.	GRID NO.
5XC-11102-20	B - 2	1HX-12168-R1	B - 5	5BE-13447-10	B - 12	5JG-14546-01	B - 14	4MX-14943-92	B - 15	5NL-15451-00	C - 6
5XC-11133-10	B - 2	1HX-12168-U1	B - 5	5XC-13464-30	B - 10	676-14548-00	C - 2	4MX-14943-93	B - 14	5NL-15453-10	C - 6
5NL-11134-10	B - 2	1HX-12168-W1	B - 5	5XC-13465-30	B - 10	4MX-14561-00	C - 3	4MX-14943-94	B - 15	5NL-15462-00	C - 6
5XC-11166-00	B - 2	1HX-12168-Y1	B - 5	5XC-13597-30	B - 13	6H4-14561-00	C - 2	4MX-14943-95	B - 15	5NL-15601-20	C - 8
371-11167-01	B - 2	1HX-12169-11	B - 6	5XC-14101-G0	B - 14	5NX-14562-00	C - 3	5XC-14947-00	B - 14	5XC-15620-10	C - 8
5NL-11181-00	B - 2	1HX-12169-31	B - 6	5XC-14101-H0	B - 14	3TJ-14564-40	C - 2	4MX-14948-02	B - 15	5XC-15621-10	C - 8
5NL-11191-20	B - 2	1HX-12169-50	B - 6	5NL-14105-00	C - 2	5JG-14565-00	C - 3	4MX-14948-03	B - 15	5NL-15641-20	C - 8
5NL-11193-00	B - 2	1HX-12169-70	B - 6	4MX-14115-00	C - 3	5NL-14591-00	C - 3	4MX-14948-04	B - 15	5NL-15651-00	C - 8
5UM-1119E-00	B - 2	1HX-12169-90	B - 6	3TJ-14137-40	B - 13	688-14592-00	B - 14	4MX-14948-05	B - 15	5NL-15664-00	C - 8
5XC-11311-10	B - 3	1HX-12169-E0	B - 6			5XC-14611-20	C - 4	4MX-14948-06	B - 15	5SG-15668-00	C - 8
5NL-11351-00	B - 3	1HX-12169-G0	B - 6	5BE-14146-00	C - 3	5NL-14613-00	C - 4	4JT-1494F-03	B - 15	2S2-15671-00	C - 8
5XC-11400-20	B - 4	1HX-12169-J0	B - 6	5PA-14146-00	C - 3	5XC-14628-00	C - 4	4JT-1494F-07	B - 15	214-15686-00	C - 8
5UL-11412-20	B - 4	1HX-12169-L0	B - 6	5TA-14155-00	C - 2	5XC-1469A-00	C - 4	4JT-1494F-11	B - 15	5NL-16111-00	C - 9
5UL-11422-10	B - 4	1HX-12169-N0	B - 6	633-14159-00	C - 2	5XC-1469A-10	C - 4	3TJ-1494F-13	B - 15	5NL-16150-10	C - 9
5NL-11454-00	B - 4	1HX-12169-T0	B - 6	3TJ-14159-40	B - 14		F - 3	3TJ-1494F-14	B - 15	5NL-16154-00	C - 9
5NL-11455-00	B - 4	5UL-12170-10	B - 7	5XC-14171-00	C - 2	2S2-1469E-00	C - 4	3TJ-1494F-15	B - 15	3XJ-16321-00	C - 9
5NL-11531-00	B - 4	5UL-12180-10	B - 7	3TJ-14191-40	C - 2		F - 3	4JT-1494F-15	B - 15	5DH-16321-00	C - 9
5NL-11536-00	B - 4	5TA-12210-20	B - 7	5UL-14196-00	C - 3	2S2-1469F-00	C - 4	3TJ-1494F-16	B - 15	5NL-16325-00	C - 9
5NL-11603-00	B - 4	4FM-12213-00	B - 7	5TA-14197-00	C - 3		F - 3	3TJ-1494F-17	B - 15	5NL-16325-10	C - 9
5NL-11631-20	B - 4	5BE-12241-00	B - 7	5NX-14216-00	C - 3	5XD-14714-00	C - 4	3TJ-1494F-18	B - 15	5HD-16351-00	C - 9
5NL-11633-00	B - 4	5NL-12251-10	B - 7	5TA-14227-00	B - 13		F - 3	3TJ-1494F-19	B - 15	5NL-16356-00	C - 9
5XC-11651-00	B - 4	5NL-12252-00	B - 7	5TA-14239-00	B - 13	5BE-14747-00	C - 4	4JT-1494F-19	B - 15	5NL-16357-10	C - 9
5XC-11681-00	B - 4	5XC-1240A-G0	B - 9	5TA-14261-00	C - 3		F - 3	4JT-1494F-23	B - 15	5NL-16371-00	C - 9
5NL-12111-20	B - 5	5NL-12422-10	B - 8	5JG-14264-00	B - 14	5XC-14750-30	C - 4	4JT-1494F-27	B - 15	5JG-16381-10	C - 9
5NL-12112-20	B - 5	5NL-12439-00	B - 8	3TJ-14267-40	B - 14	5XC-14750-40	C - 4	4JT-1494F-29	C - 2	5NL-16383-10	C - 9
5NL-12113-00	B - 5	5DH-12451-00	B - 8	5JG-14275-00	B - 14	5XC-14750-50	F - 3	5JG-14951-00	B - 14	4JT-16384-00	C - 9
5NL-12114-00	B - 5	5XC-12459-00	B - 8	5TA-14293-00	B - 13	4BD-14766-00	C - 4	5JG-14959-00	B - 14	5NL-16384-00	C - 9
5NL-12116-00	B - 5	5XC-12461-G0	B - 9	3TJ-14293-40	C - 2	5BE-14788-00	C - 4	5JG-14984-00	C - 2	5NL-17121-00	C - 11
1HX-12117-00	B - 5	22W-12462-00	B - 9	5XD-14325-00	C - 3	5NL-14916-P1	B - 14	4SR-14985-00	C - 2	5NL-17131-10	C - 11
1WG-12117-00	B - 5	2S2-12464-70	B - 9	5TA-14335-00	C - 2	5NL-14916-PM	B - 14	5TA-14987-00	B - 13	5NL-17141-11	C - 11
1HX-12118-00	B - 5	5XC-12481-G0	B - 9	5JG-14346-00	C - 3	5NL-14916-PN	B - 14	5TJ-14987-00	C - 3	5NL-17151-00	C - 11
1WG-12118-00	B - 5	1C3-12482-00	B - 9	5TA-14371-00	C - 2	5NL-14916-PP	B - 14	5TA-14991-00	C - 2	5NL-17211-10	C - 11
4SV-12119-00	B - 5	5Y9-12491-00	E - 15	2S2-14374-00	C - 2	5NL-14916-PR	B - 14	4FN-14997-00	B - 14	5NL-17221-00	C - 11
4TV-12119-00	B - 5	5NL-12564-00	C - 6	5JG-14379-00	C - 2	5NL-14916-PS	B - 14	5TA-14997-00	C - 2	5NL-17231-11	C - 11
5NL-12121-10	B - 5	5XC-12576-G0	B - 9	2S2-14388-00	B - 14	5NL-14916-PT	B - 14	5XC-15118-00	C - 7	5NL-17241-11	C - 11
3GM-12126-00	B - 5	5XC-12578-G0	B - 9	4MX-14392-00	C - 2	5XC-14922-00	C - 2	5XC-15150-20-YX	C - 5	5NL-17251-10	C - 11
3FV-12153-10	B - 6	5XC-12579-G0	B - 9	2S2-14401-70	B - 13	3TJ-14933-40	C - 2	3Y1-15361-00	C - 7	5NL-17402-00	C - 11
3LN-12153-10	B - 6	583-13113-00	B - 12	5XC-14417-90	B - 13	5TA-14934-00	C - 3	3Y1-15363-00	C - 6	5NL-17411-10	C - 11
1HX-12168-00	B - 5	5NL-13161-20	B - 12	5NY-14442-00	B - 13	5JG-14940-16	C - 2	5XC-15373-00	C - 6	5NL-17466-00	C - 5
1HX-12168-20	B - 5	5NL-13171-00	B - 12	4XM-14451-00	B - 13	5JG-14940-17	C - 2	2S2-15378-00	C - 7	5NL-17471-10	C - 12
1HX-12168-40	B - 5	5SG-13300-00	B - 10	5XC-14453-G0	B - 13	5JG-14940-18	C - 2	4JT-15381-01	C - 5	5UL-18101-10	C - 14
1HX-12168-60	B - 5	5NL-13320-00	B - 10	5NY-14455-20	B - 13	5JG-14940-76	C - 2	5BE-15383-01	C - 5	5XC-18110-00	C - 14
1HX-12168-80	B - 5	5NL-13341-00	B - 10	5BE-14458-00	B - 13	5TA-14943-28	C - 2	5NL-15388-00	C - 5	5LP-18122-01	C - 14
1HX-12168-A0	B - 5	5BE-13342-00	B - 10	5NY-14459-00	B - 13	4MX-14943-41	B - 14	5NL-15411-20	C - 6	3XK-18140-00	C - 13
1HX-12168-F0	B - 5	5NL-13411-00	B - 10	5JG-14521-00	B - 14	4MX-14943-42	B - 15	5NL-15415-10	C - 6	5BE-18172-00	C - 14
1HX-12168-H1	B - 5	5XC-13412-00	B - 10	5JG-14522-00	B - 14	4MX-14943-43	B - 15	5BE-15421-10	C - 5	3XJ-18173-10	C - 14
1HX-12168-K1	B - 5	5XC-13416-90	D - 5	5JG-14531-00	C - 3	4MX-14943-44	B - 15	5XC-15431-01	C - 6	3XJ-18178-00	C - 14
1HX-12168-M1	B - 5	5TA-13440-00	B - 12	3TJ-14536-40	C - 2	4MX-14943-91	B - 14	5NL-15441-01	C - 5	3XJ-18182-00	C - 14

NUMERICAL INDEX

PART NO.	GRID NO.	PART NO.	GRID NO.	PART NO.	GRID NO.	PART NO.	GRID NO.	PART NO.	GRID NO.	PART NO.	GRID NO.
3XJ-18184-00	C - 14	3RV-21668-B0	D - 8	5UN-22212-F0	F - 2	5XE-23153-L0	D - 12	5XC-2470F-90	E - 3	1C3-25872-90	E - 10
2S2-18185-00	C - 14	5XC-21710-90	D - 5	5UN-22212-G0	F - 2	2HH-23158-L0	D - 12	5XC-2470F-A0	E - 3	1C3-25873-00	E - 12
5NL-18501-00	C - 13	5XC-21720-90	D - 5	1C3-22213-L0	D - 9	1C3-2315H-10	D - 14	5XC-2470F-B0	E - 3	1C3-25876-50	E - 12
5NL-18502-00	C - 13	2S2-2172A-70	D - 5	1C3-22214-50	D - 9	1C3-2315J-10	D - 14	2S2-24710-70	E - 3	1C3-25886-50	E - 12
5NL-18503-00	C - 13	2S2-2172A-80	D - 5	5MV-22224-00	D - 9	5XC-2316A-R0	D - 12	2S2-24710-80	E - 3	5MV-2589F-00	E - 10
5NL-18541-00	C - 13	2S2-21730-70	D - 5	4JX-22226-00	D - 9	5XC-2316A-S0	D - 12	5XC-24710-A0	E - 3	5UN-25914-00	E - 8
4UN-18542-00	C - 13	5XC-21730-90	D - 5	3SP-22234-00	D - 9	5XC-23170-M0	D - 12	5XC-24710-B0	E - 3	5DH-25914-50	E - 8
5DH-18562-00	C - 5	5XC-2173E-10	D - 5	5NY-22241-00	D - 10	5XC-23170-N0	D - 12	5NY-25104-00	E - 4	3SP-25914-51	E - 5
5XC-21101-G0	C - 15	5XC-2173F-10	D - 5	5XE-22242-00	D - 10	5XE-23171-L0	D - 12	5NY-25111-00	E - 4	5DH-25916-00	E - 5
5XC-21163-90	D - 2	5XC-2173L-10	D - 5	1C3-22253-50	D - 9	5DH-23183-00	D - 9	5NY-25117-00	E - 4		E - 8
5XC-21164-90	D - 2	2S2-21740-70	D - 5	1C3-22253-L0	D - 9	509-23184-L0	D - 9	5XC-25181-G0	E - 4	3JD-25917-00	E - 5
5PA-2118K-00	D - 3	5XC-21740-90	D - 5	4AA-22259-40	D - 9	1C3-23188-L0	D - 12	5XC-25183-G0	E - 4		E - 8
5PA-2118K-10	D - 3	5XC-2174L-10	D - 5	4AA-22259-50	D - 9	1C3-23188-N0	D - 12	5XC-25186-G0	E - 4	5DH-25919-00	E - 5
5PA-2118K-20	D - 3	5XC-21751-G0	D - 5	4AA-22259-60	D - 9	1C3-23188-P0	D - 12	5HD-25304-00	E - 6	5DH-25919-50	E - 8
2S2-21190-70	C - 15	2S2-22110-70	D - 7	4AA-22259-80	D - 9	1C3-23188-R0	D - 12	5TJ-2530S-80	E - 7	8CR-25924-00	E - 8
1C3-21244-10	D - 2	5XC-22121-91	D - 8	1C3-22355-00	D - 7	1C3-23190-L0	D - 12	5ET-25311-00	E - 6	3SP-25926-51	E - 5
5XC-21274-90	D - 2	1C3-22122-00	D - 8	4EW-22474-00	D - 9	5XC-23340-N0	D - 14	5ET-25317-00	E - 6	5DH-25933-00	E - 5
5XC-21288-90	D - 2	2S2-22128-70	D - 7	3JE-22475-00	D - 9	3SP-23356-L0	D - 14	4XM-25364-00	E - 6	1UY-25937-51	E - 5
1C3-2135F-00	D - 8	1C3-22141-10	D - 7	5NY-22475-00	D - 9	5XE-23389-00	D - 11	1C3-25381-90	E - 7		E - 8
1C3-2139R-00	D - 8	2S2-22151-70	D - 7	1C3-22565-00	D - 9	4EW-23416-00	D - 11	1C3-25388-50	E - 7	1C3-26111-90	E - 9
5XC-21417-G0	D - 2	5UN-22176-00	D - 9	5UN-22898-60	E - 8	2S2-23435-70	D - 11	1C3-25389-00	E - 7	5XC-26124-90	E - 9
5XC-21418-G0	D - 2	30X-22178-00	C - 15	1C3-22969-90	D - 7	5XC-23441-90	D - 11	4XM-25394-00	E - 6	2S2-26143-70	E - 9
5XC-21425-G0	C - 15	3JD-22178-20	C - 15	5XC-23102-G0	D - 12	2S2-23442-70	D - 11	5SF-25394-00	E - 4	5XC-26143-90	E - 9
5XC-21426-G0	C - 15	5XC-2217A-G0	D - 7	5XC-23102-H0	D - 12	1C3-23466-50	D - 14	1C3-25447-00	E - 6	5TJ-26240-C0	E - 9
1C3-21447-10	C - 15	5XC-2217F-G0	D - 7	5XC-23103-G0	D - 13	1C3-23467-50	D - 14	1C3-25448-00	E - 6	4GY-26241-00	E - 9
1C3-21448-10	C - 15	4V4-22184-00	C - 15	5XC-23103-H0	D - 13	1C3-23485-80	D - 11	1C3-25449-00	E - 6	4GY-26242-00	E - 9
5XC-21456-90	D - 2	5MV-22184-00	D - 9	5XC-23110-M0	D - 13	2S2-24110-70	D - 15	1C3-25450-00	E - 6	3Y1-26249-00	E - 9
5XC-21471-90	D - 2	2S2-22199-70	D - 7	1C3-23111-L1	D - 12	4EW-2412F-00	D - 15	1C3-25451-00	E - 6	5BE-26281-00	E - 9
5XC-2147E-G0	D - 2	5XC-22200-G0	D - 9	276-23114-00	D - 12	5XE-24144-00	D - 15	1C3-25452-00	E - 6	5BE-26282-00	E - 9
5XC-21486-90	D - 2	5XC-22200-H0	D - 9	5XC-23120-M0	D - 12	3FB-2415E-01	D - 3	5CG-25715-00	E - 10	5SF-26287-10	E - 9
1C3-21511-51	D - 3	5XC-22200-J0	D - 9	5XE-23125-L0	D - 12	3ME-2415E-01	D - 4		E - 12	5XC-26302-G0	E - 9
2S2-21511-70	D - 3	5XC-22200-K0	D - 9	1C3-23136-N0	D - 12	3FB-2415E-11	D - 3	1C3-25718-50	E - 8	5XC-26334-G0	E - 14
4LB-2151H-02	D - 3	5XC-22200-L0	D - 9	1C3-23141-A1	F - 2	3FB-2415E-C0	D - 3	5XC-2580T-G0	E - 5	5XC-26335-G0	E - 9
3XJ-2151H-A1	D - 3	5XC-22201-G0	D - 9	1C3-23141-B1	F - 2	4SR-2416E-00	D - 3	1C3-2580W-50	E - 8	5HD-26337-00	E - 14
3XJ-2151H-B1	D - 4	5XC-22201-H0	D - 9	1C3-23141-C1	F - 2	5XC-24181-90	D - 15	5XC-2581T-G0	E - 5	5TA-26339-00	E - 14
4XL-2153A-10	D - 14	1C3-22212-00	F - 2	1C3-23141-E1	F - 2	5XC-24182-90	E - 2	5UN-25827-60	E - 8	1C3-26342-50	E - 9
5XC-2153E-00	D - 3	5UN-22212-00	F - 2	1C3-23141-F1	F - 2	5XC-24183-90	E - 2	5UN-25828-60	E - 8	5HD-26372-00	E - 14
4ES-2153E-01	D - 3	1C3-22212-10	F - 2	1C3-23141-G1	F - 2	3JD-24186-00	D - 15	2S2-2582W-70	E - 8	5XC-26372-G0	E - 10
5XC-2153E-10	D - 3	1C3-22212-20	D - 9	1C3-23141-H1	F - 2	5UM-2419A-E0	D - 15	5MV-25833-00	E - 10	5UM-27200-00	E - 11
4ES-2153E-20	D - 3	1C3-22212-30	F - 2	1C3-23141-J1	F - 2	5XC-24311-G0	D - 15	1C3-2583V-00	E - 12	5UN-27217-00	E - 12
5PA-21568-00	D - 4	1C3-22212-40	F - 2	1P8-23141-M1	D - 12	5XC-24339-90	D - 15	5XC-25849-G0	E - 5	5XC-27217-90	E - 11
2S2-21610-70	D - 3	1C3-22212-50	F - 2	1C3-23142-L0	D - 12	3XJ-24380-00	D - 15	5UN-25852-50	E - 12	5UN-27218-00	E - 12
5XC-21610-90	D - 3	1C3-22212-60	F - 2	5XE-23144-L0	D - 12	4JT-24500-10	D - 15	5XC-25852-G0	E - 10	5UN-27222-00	E - 12
5XE-21635-10	D - 3	5UN-22212-A0	F - 2	1C3-23145-M0	D - 12	4X8-24512-00	D - 15	5XC-25853-G0	E - 10	1C3-27311-00	E - 11
5XC-2163G-10	D - 4	5UN-22212-B0	F - 2	5XE-23146-L0	D - 12	3AC-24523-00	D - 15	5UN-25854-00	E - 12	5XE-27411-01	E - 11
5TA-21642-00	D - 3	5UN-22212-C0	F - 2	1AE-23147-00	D - 12	3AJ-24534-01	D - 15	5XC-25854-G0	E - 10	5XE-27421-01	E - 11
2S2-2165A-00	D - 4	5UN-22212-D0	F - 2	1C3-23147-L0	D - 12	5NY-24610-00	D - 15	5UN-2585B-00	E - 12	1C3-27491-50	E - 8
3RV-21668-A0	D - 8	5UN-22212-E0	F - 2	1C3-2314F-M0	D - 12	2S2-2470F-80	E - 3	5MV-25867-00	E - 10	5XC-28116-00	D - 2

NUMERICAL INDEX

PART NO.	GRID NO.	PART NO.	GRID NO.	PART NO.	GRID NO.	PART NO.	GRID NO.	PART NO.	GRID NO.	PART NO.	GRID NO.
5TA-2814F-00	D - 2	90105-06108	E - 8	90152-06010	C - 8	90201-177G4	C - 8	90401-10015	B - 12	91312-06016	D - 5
5ET-28166-10	D - 2	90105-06110	E - 8	90154-05022	E - 15	90201-20020	E - 7	90401-10172	E - 10	91312-06020	B - 9
5UL-82310-10	E - 15	90105-06111	B - 9	90159-06092	C - 9	90201-20685	C - 8		E - 12	91312-06025	B - 10
5XC-82509-00	E - 15		D - 15	90170-14171	B - 4	90201-21014	D - 7	90430-06014	B - 2		B - 12
5XC-82540-00	E - 15		E - 8	90170-16326	C - 9	90201-24016	D - 11		B - 8		B - 13
5XE-82911-00	E - 14	90105-06112	D - 6	90170-24003	D - 11	90201-286K9	D - 11	90430-08119	B - 12	91312-06045	C - 5
5XD-82913-00	E - 14	90105-06128	D - 5	90179-06028	D - 7	90202-05193	E - 2	90430-10005	E - 10	91312-06055	C - 5
5XD-82946-00	E - 14	90105-08137	C - 4	90179-08674	E - 7	90202-08045	B - 14		E - 12	91312-06065	B - 12
5MV-83912-00	E - 14		E - 5	90179-10658	C - 15	90206-06090	C - 4	90430-10188	B - 12	91312-06070	C - 5
5XC-83922-G0	E - 10	90105-08143	D - 2	90179-12657	E - 13	90209-06014	B - 13		C - 5	91316-04012	B - 14
5TA-83941-00	E - 14	90105-08146	C - 15	90179-16011	E - 4	90209-16011	D - 7	90445-09220	D - 15	91317-06030	B - 10
5HD-83951-00	E - 14	90105-08147	C - 15	90179-18001	C - 9	90209-20008	C - 11	90445-09251	D - 15	91402-20012	E - 11
1C3-83976-00	E - 14	90105-08150	C - 15		C - 12	90209-23012	C - 11	90445-14010	B - 11	91402-25015	E - 11
5LP-84126-10	E - 14	90105-08151	D - 5	90179-28003	D - 11	90215-14204	B - 4	90450-17001	B - 11	91808-16023	B - 2
5XC-85540-G0	E - 15	90105-08154	D - 11	90183-060A6	B - 9	90215-16289	C - 9	90450-22001	B - 9	91812-16001	C - 6
1C3-85546-00	E - 15		D - 14	90185-08008	E - 7	90215-20003	C - 9		B - 10	91A20-05065	B - 9
5TA-85550-00	E - 13	90105-08156	C - 15	90185-08009	C - 15		C - 11	90450-25001	B - 9	92012-05008	D - 2
5XC-85560-00	E - 13	90105-08307	C - 4	90185-10012	D - 10	90240-08120	E - 11	90450-32003	B - 9	92012-05012	E - 14
5XC-85885-00	C - 3		C - 15	90185-14010	D - 8	90240-10004	E - 11	90450-57010	B - 13	92012-06010	B - 9
5XC-W0041-00	E - 10	90105-09002	B - 2	90185-16002	D - 7	90267-32070	B - 13	90450-61002	B - 13	92902-06600	B - 7
5UN-W0042-50	E - 12	90105-09004	B - 2	90185-20002	E - 7	90267-48084	C - 4	90464-13073	E - 15	92902-08200	D - 2
5XC-W0045-00	E - 5	90105-10174	C - 15	90201-03313	B - 13		F - 3	90464-13077	E - 15	92902-10200	D - 10
1C3-W0046-50	E - 8	90105-10176	D - 2	90201-06032	D - 3	90280-03006	B - 4	90464-15195	E - 15		D - 11
5KM-W0047-10	E - 5	90105-10191	C - 15	90201-06570	D - 15	90340-12007	B - 2	90465-08029	C - 7	93101-14164	C - 6
5UN-W0047-50	E - 8	90109-06034	E - 14	90201-06571	B - 9	90340-14128	C - 6	90465-10013	C - 5	93102-12106	B - 8
1UY-W0048-50	E - 5	90109-06193	C - 13		D - 3	90340-32123	C - 6	90465-13275	E - 2	93102-12224	C - 9
	E - 8	90109-067F4	B - 13		D - 6	90387-06009	D - 3		E - 15		C - 14
5XC-W0057-00	E - 5	90109-08078	E - 7	90201-06630	D - 5	90387-06065	B - 9	90467-090A2	B - 9	93102-18278	C - 8
5UN-W0057-50	E - 8	90110-05038	B - 13	90201-08043	C - 15		D - 15	90467-100A1	E - 2	93102-26468	E - 4
5XC-W2587-00	E - 10	90110-06228	B - 12	90201-08044	E - 11	90387-06090	D - 3	90467-140A4	B - 2	93102-28010	C - 11
90101-06041	C - 14	90110-08051	C - 8	90201-08045	C - 15		D - 15	90468-16001	E - 11	93106-22002	D - 7
90101-06044	C - 8	90111-06059	E - 12	90201-08048	C - 8	90387-06104	D - 11	90480-08608	E - 7	93106-30001	E - 6
90101-08006	E - 7	90116-06038	B - 2		E - 7	90387-06150	D - 6	90480-10289	D - 5	93106-30045	E - 6
90105-05014	D - 2	90119-06146	D - 2	90201-08061	C - 4	90387-06161	D - 6	90480-14433	D - 6	93109-11073	B - 8
90105-06027	B - 2	90119-06147	D - 3	90201-080H1	C - 9	90387-08041	C - 15	90480-15528	B - 9	93109-21001	D - 8
90105-06064	D - 5	90119-06151	D - 11	90201-082A6	D - 5	90387-08081	C - 4	90480-18549	D - 15	93109-25001	D - 7
90105-06081	C - 5	90119-08095	D - 5	90201-08410	C - 3		F - 3	90501-043E0	B - 12	93109-28043	D - 7
	C - 12	90122-06005	B - 13	90201-08512	B - 8	90387-086N4	C - 15	90501-052G5	C - 14	93210-07003	B - 12
90105-06094	C - 7	90149-05162	E - 14	90201-096J9	B - 2	90387-124F4	C - 14	90501-06022	C - 13	93210-07135	B - 12
90105-06098	C - 6	90149-06074	C - 5	90201-10032	E - 11	90387-14005	D - 8	90501-147A5	C - 8	93210-09008	B - 12
90105-06100	D - 3	90149-06084	B - 4	90201-10045	C - 15	90387-16010	D - 7	90501-160A2	C - 8	93210-09754	B - 11
90105-06103	D - 5	90149-06085	C - 5	90201-12166	B - 10	90387-18004	D - 7	90501-224J9	C - 9	93210-10197	B - 10
90105-06104	D - 7	90149-06108	E - 2	90201-127E1	E - 13	90387-18007	C - 5	90506-16007	E - 11		C - 5
90105-06105	D - 7	90149-06121	E - 13	90201-14020	D - 8	90387-18012	D - 7	90508-26561	C - 13	93210-11073	E - 11
90105-06106	D - 3	90149-06327	E - 5	90201-15701	C - 6	90387-20006	C - 11	90508-28015	E - 11	93210-12759	B - 12
90105-06107	D - 11	90149-10031	C - 15	90201-16018	D - 7	90387-22001	C - 11	90508-28018	E - 11	93210-14369	C - 6
	D - 15	90151-04003	D - 7	90201-162H4	C - 8	90387-225N2	E - 9	90508-291A8	C - 14		D - 5
	E - 8	90151-06032	D - 2	90201-167P7	C - 8	90401-08006	B - 12	90508-30743	C - 8	93210-16275	B - 9

NUMERICAL INDEX

PART NO.	GRID NO.	PART NO.	GRID NO.	PART NO.	GRID NO.	PART NO.	GRID NO.	PART NO.	GRID NO.	PART NO.	GRID NO.
93210-16716	C - 6	94108-21015	E - 4	98502-05010	E - 12						
93210-17570	C - 8	94108-2112Y	E - 4	98502-05020	E - 9						
93210-19123	C - 6	94110-19009	E - 6	98502-06025	C - 5						
93210-196A4	C - 11	94110-19012	E - 6	98702-06025	D - 15						
93210-21276	E - 15	94110-1913B	E - 6	98706-04012	E - 10						
93210-32172	C - 6	94209-21229	E - 4	98980-06008	C - 4						
93210-47675	B - 12	94210-19222	E - 6	99001-08600	B - 10						
93300-60839	C - 15	94210-19224	E - 6	99009-12400	B - 10						
93306-00105	B - 8	94227-21101	E - 4	99009-16400	C - 8						
93306-00317	C - 11	94309-21161	E - 4	99009-17400	C - 8						
93306-00320	C - 11	94316-19156	E - 6	99009-22500	C - 6						
93306-07202	E - 6	94321-19135	E - 6	99009-45500	E - 6						
93306-20335	B - 4	94330-21084	E - 4	99530-08012	B - 10						
93306-20447	C - 11	94416-21034	E - 4	99530-08016	C - 6						
93306-20648	B - 4	94418-19008	E - 6	99530-10114	B - 10						
93306-27208	C - 11	94591-53114	B - 7		C - 5						
93306-27212	E - 6	94681-68001	E - 7	99530-10116	C - 5						
93306-90409	E - 4	94701-00410	B - 2	9Y581-92111	E - 7						
93306-90509	C - 13	94701-00411	B - 2								
93310-63238	B - 4	94703-00410	B - 2								
93311-32261	B - 4	94703-00411	B - 2								
93315-32166	D - 7	95022-06010	B - 2								
93317-11287	C - 9		C - 10								
93317-22262	D - 7	95022-06012	B - 8								
93332-00068	D - 11		B - 12								
93332-00081	D - 14	95022-06016	B - 10								
93340-21008	C - 9	95022-06020	C - 14								
93342-22217	D - 7	95022-06025	B - 7								
93410-20038	C - 8		B - 8								
93410-22039	C - 11		B - 10								
93410-26067	C - 11		C - 6								
93420-16086	B - 4	95022-06035	B - 3								
93440-07149	B - 2		C - 6								
93440-07182	B - 8	95022-06065	B - 8								
	C - 9	95022-08040	C - 15								
93440-10153	B - 2	95022-10016	C - 5								
	B - 10	95602-05100	E - 14								
93440-41178	B - 7	95602-10200	D - 10								
93503-08007	B - 12		D - 11								
93507-32009	C - 8	95612-08620	B - 2								
93511-32027	C - 9	95701-06500	E - 10								
93603-16219	B - 10	95702-06500	B - 3								
93604-10011	B - 8		D - 14								
93608-33002	C - 14	95702-08500	B - 2								
93612-16254	B - 3	97002-05016	E - 14								
	C - 5	97022-06016	B - 7								
9383B-13218	C - 11	97702-60016	D - 3								
94108-21012	E - 4	98502-03008	D - 15								